

CBCS SCHEME

USN

4	V	P	9	D	C	S	0	9	8
---	---	---	---	---	---	---	---	---	---

18CIV14/24

First/Second Semester B.E. Degree Examination, Jan./Feb. 2021

Elements of Civil Engineering and Mechanics

Time: 3 hrs.

Max. Marks: 100

- Note:** 1. Answer any FIVE full questions, choosing ONE full question from each module.
 2. Missing data, if any, may be suitably assumed.

Module-1

- 1 a. Explain briefly the scope of following areas of civil engineering :
 - i) Irrigation engineering (10 Marks)
 - ii) Environmental engineering. (10 Marks)
- b. What are the roles of civil engineers in the infrastructural development of a country? (10 Marks)

OR

- 2 a. State and explain basic idealization in mechanics. (06 Marks)
- b. State and prove law of parallelogram of forces. (06 Marks)
- c. Two forces acting on a body are 500N and 1000N as shown in Fig.Q2(c). Determine the third force F such that the resultant of all the three forces is 1000N, directed at 40° to the X axis.

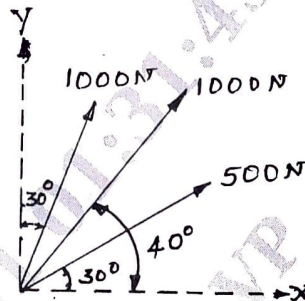

Fig.Q2(c)

(08 Marks)

Module-2

- 3 a. State and prove Lami's theorem. (08 Marks)
- b. Two identical cylinders, each weighing 500N are arranged in a through as shown in Fig.Q3(b). Determine the reactions developed at contact points A, B, C and D. Assume all points of contact are smooth.

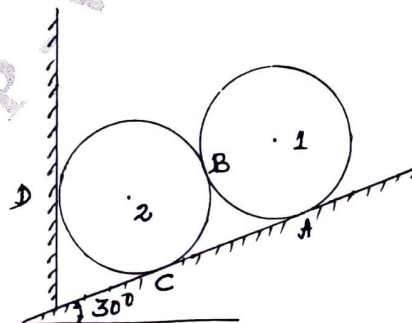

Fig.Q3(b)

(10 Marks)

- c. List the equations of equilibrium. (02 Marks)

Important Note : 1. On completing your answers, compulsorily draw diagonal cross lines on the remaining blank pages.
 2. Any revealing of identification, appeal to evaluator and /or equations written eg. 42+8 = 50, will be treated as malpractice.

OR

- 4 a. State the laws of dry friction. (04 Marks)
 b. Explain the types of friction. (06 Marks)
 c. Find the force p just required to slide the block B in the arrangement shown in Fig.Q4(c). Find also the tension in the string. Given weight of block A = 500N and weight of block B = 1000N. $\mu = 0.2$ for all contact surfaces.

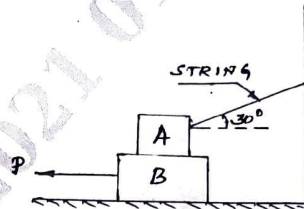

Fig.Q4(c)

(10 Marks)

Module-3

- 5 a. Explain with sketches different types of loads. (04 Marks)
 b. Explain with sketches different types of supports. (06 Marks)
 c. Determine the reactions developed at supports A and B of overhanging beam shown in Fig.Q5(c).

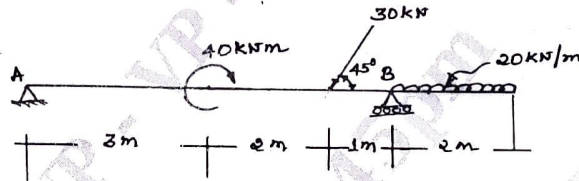

Fig.Q5(c)

(10 Marks)

OR

- 6 a. List the different types of trusses. (06 Marks)
 b. Analyse the truss shown in Fig.Q6(b) by method of joints.

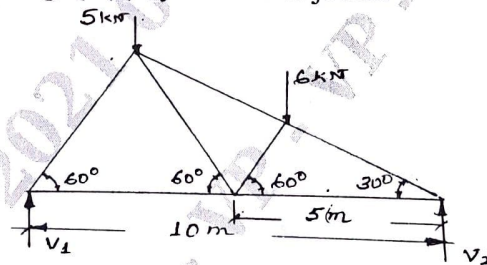

Fig.Q6(b)

(14 Marks)

Module-4

- 7 a. Determine the centroid of a semicircular lamina from the first principle. (08 Marks)
 b. Locate the centroid of the lamina shown in Fig.Q7(b), with respect to axes 1-1 and 2-2.

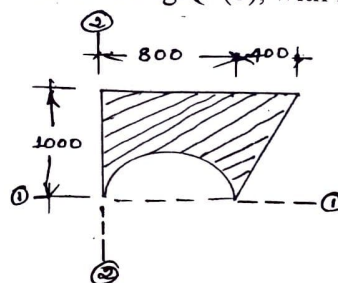

Fig.Q7(b)

(12 Marks)

OR

- 8 a. State and prove parallel axes theorem. (08 Marks)
 b. Determine the moment of inertia of the symmetric I-section shown in Fig.Q8(b) about its centroidal axes x-x and y-y.

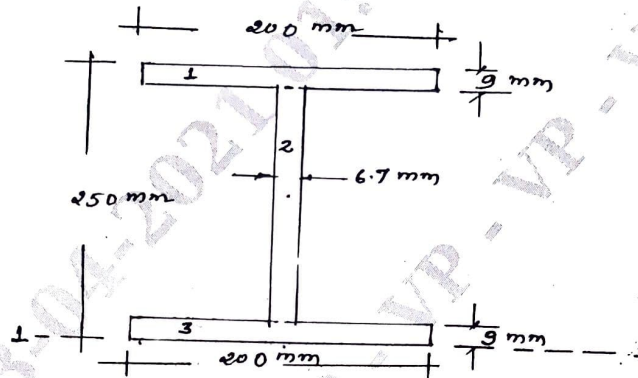

Fig.Q8(b)

(12 Marks)

Module-5

- 9 a. Define the following :
 i) Projectile
 ii) Trajectory
 iii) Time of flight
 iv) Range. (08 Marks)
 b. A projectile is fired at certain angle has a horizontal range of 3.5km. If the maximum height reached is 500m, what is the angle of elevation of the cannon? What was the muzzle velocity of the projectile? (06 Marks)
 c. A Burglar's car starts with an acceleration of 2m/sec^2 . A police van came after 10 sec and continued to chase the burglar's car with a uniform velocity of 40m/sec. find the time taken by the police van to overtake the Burglar's car. (06 Marks)

OR

- 10 a. State Newton's second law of motion and D'Alembert's principle. (04 Marks)
 b. A lift carries a man of weight 4000kN and is moving with a uniform acceleration of 3.5m/sec^2 . Determine the tension in the cable when :
 i) Lift is moving upwards
 ii) Lift is moving downwards. (08 Marks)
 c. A car travelling at a speed of 75kmph applies brake and comes to a halt after skidding 60m. Determine :
 i) Deceleration
 ii) Time to stop the car
 iii) Coefficient of friction between road and tyres. (08 Marks)

* * * * *