



USN

--	--	--	--	--	--	--	--	--	--

18CIV14/24

First/Second Semester B.E. Degree Examination, Aug./Sept.2020 Element of Civil Engineering and Mechanics

Time: 3 hrs.

Max. Marks: 100

- Note: 1. Answer any FIVE full questions, choosing ONE full question from each module.
2. Missing data, if any, may be suitably assumed.

Module-1

1. a. Explain Briefly the scope of :
 - i) Construction Technology (08 Marks)
 - ii) Environmental Engineering. (08 Marks)
- b. Explain the role of civil engineer in the infrastructure development of the country. (08 Marks)
- c. State and explain the law of transmissibility of forces. (04 Marks)

OR

2. a. State and prove Varignon's theorem of moments. (08 Marks)
- b. Replace the horizontal force acting at A by an equivalent force acting at a B and a couple. Refer Fig.Q2(b).

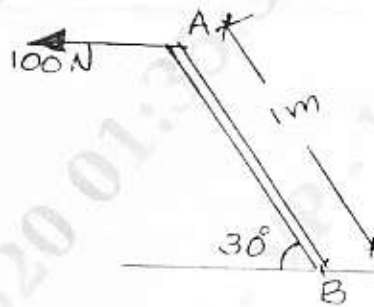

Fig.Q2(b)

(05 Marks)

- c. For the non-concurrent coplanar system shown in Fig.Q2(c), determine the magnitude, direction and position of the resultant force with reference to A.

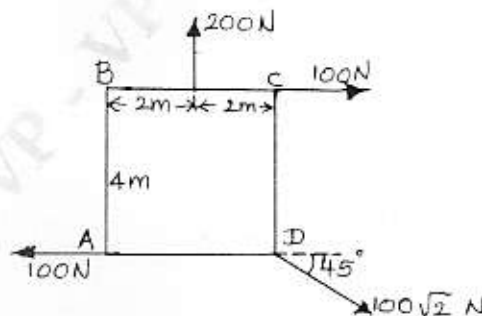

Fig.Q2(c)

(07 Marks)

Important Note : 1. On completing your answers, compulsorily draw diagonal cross lines on the remaining blank pages.
2. Any revealing of identification, appeal to evaluator and /or equations written eg. 42+8 = 50, will be treated as malpractice.

Module-2

- 3 a. State and prove Lami's theorem. (04 Marks)
 b. Two identical rollers each weighing 200N are placed in a trough as shown in Fig.Q3(b). Assuming all contact surfaces to be smooth, find the reactions development at contact surfaces A, B, C and D.

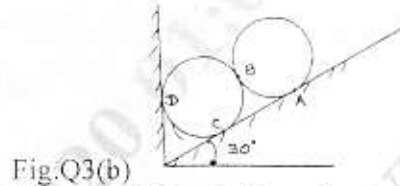

Fig.Q3(b)

(08 Marks)

- c. A string is subjected to the forces 4 kN and P as shown in Fig.Q3(c). Determine the magnitude of P and tension forces induced in various portions of the string.

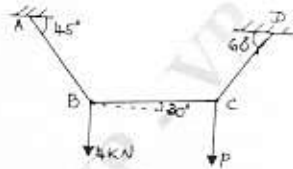

Fig.Q3(c)

(08 Marks)

OR

- 4 a. State the laws of dry friction. (04 Marks)
 b. A block of weight 1000N is resting on an inclined plane as shown in Fig.4(b). Find the magnitude of the horizontal force P to cause impending motion of the block :
 i) Up the plane ii) Down the plane. Assume coefficient of friction = 0.25.

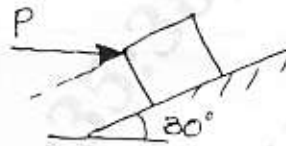

Fig.Q4(b)

(08 Marks)

- c. A ladder of length 5m and weighing 300N is placed against a vertical wall at an angle 60° with respect to the floor. The coefficient of friction between the wall and the ladder is 0.2 and that between the floor and the ladder 0.3. Calculate the minimum force (horizontal) P to be applied at the lower end of the ladder to prevent slipping when a man weighing 600N stands at a distance of 3m along the ladder from the bottom end. (08 Marks)

Module-3

- 5 a. Describe different types of supports with neat sketches showing the reactions. (08 Marks)
 b. Find the support reactions for the beam shown in Fig.Q5(b).

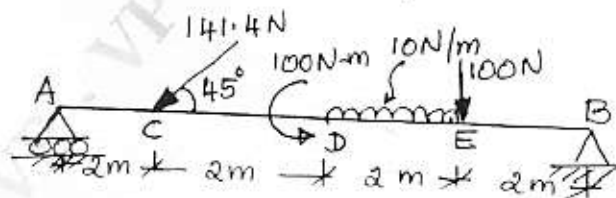

Fig.Q5(b)

(08 Marks)

- c. Find the reactions for the cantilever beam shown in Fig.Q5(c).

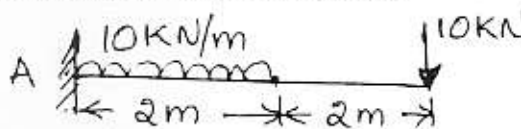

Fig.Q5(c)

(04 Marks)



OR

- 6 a. Explain different types of trusses. (06 Marks)
 b. Find the support reactions and member forces for the plane truss shown in Fig.6(b) by method of joints.

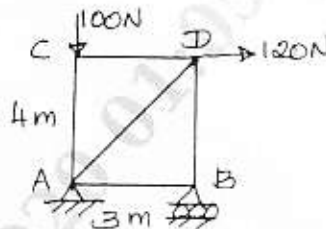

Fig.Q6(b)

(14 Marks)

Module-4

- 7 a. Derive the centroid of a triangle from first principle. (08 Marks)
 b. Locate the centroid of the shaded area with respect to the coordinate axes shown in Fig.Q7(b).

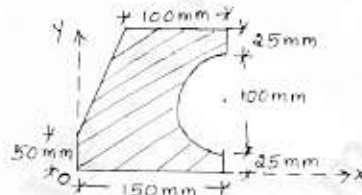

Fig.Q7(b)

(12 Marks)

OR

- 8 a. State and prove parallel axis theorem. (08 Marks)
 b. Find the polar moment of inertia for the section in Fig.Q8(b) and hence find the polar radius of gyration.

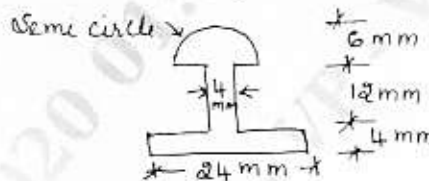

Fig.Q8(b)

(12 Marks)

Module-5

- 9 a. State Newton's laws of motion. (06 Marks)
 b. A car travels along a straight line on road. Its distance is given by the equation $S = 2.4t^2 - 0.12t^3$ where t is the time in seconds.
 i) Calculate the average velocity of the car for the time interval at $t = 0$ and $t = 15$ sec.
 ii) Calculate the instantaneous velocity of the car at $t = 5$ sec
 iii) Calculate the instantaneous acceleration of the car at $t = 5$ sec. (14 Marks)

OR

- 10 a. State D'Alembert's principle and its applications. (04 Marks)
 b. Define : i) Super elevation ii) Trajectory. (04 Marks)
 c. A ball is dropped from the top of a tower 30m high. At the same instant another ball is thrown upward from the ground with an initial velocity of 15m/s. When and where do they cross? (12 Marks)
