

CBCS SCHEME

18CIV14

First Semester B.E. Degree Examination, Dec.2018/Jan.2019 Elements of Civil Engineering and Mechanics

Time: 3 hrs.

Max. Marks: 100

Note: Answer any FIVE full questions, choosing ONE full question from each module.

Module-1

- 1 a. Briefly explain the scopes of branches:
 - i) Transportation Engineering
 - ii) Geotechnical Engineering. (10 Marks)
- b. What are the effects of infrastructural facilities on socio-economic development of a country? (05 Marks)
- c. What is the role of a civil engineer in infrastructural development of a country? (05 Marks)

OR

- 2 a. Explain briefly,
 - i) Law of physical independency of forces.
 - ii) Law of superposition of forces. (06 Marks)
- b. State and prove Varignon's law of moments. (06 Marks)
- c. Find the moment of 100kN force acting on a rigid body ABC as shown in Fig.Q.2(c), about point A. (08 Marks)

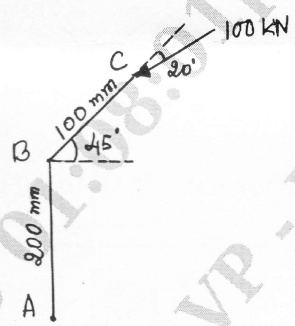

Fig.Q.2(c)

Module-2

- 3 a. Define Free Body Diagram, with the help of at least two examples. What is the importance of drawing a F.B.D (Free Body Diagram) in Engineering Mechanics? (05 Marks)
- b. What are the laws of dry friction? (05 Marks)
- c. A mass of 580 kg resting on a rough inclined plane is acted upon by a 6000N force as shown in Fig.Q.3(c). If the coefficient of friction is 0.25 at point of contact, check whether the body slides up or down. (10 Marks)

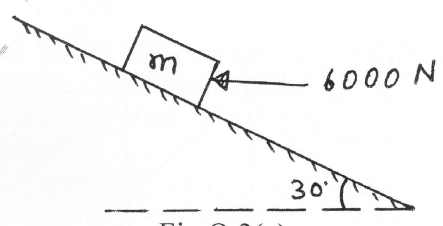

Fig.Q.3(c)

Important Note : 1. On completing your answers, compulsorily draw diagonal cross lines on the remaining blank pages.
2. Any revealing of identification, appeal to evaluator and /or equations written eg, 42+8 = 50, will be treated as malpractice.

OR

- 4 a. State and prove Lami's theorem. (04 Marks)
- b. Find the reactions developed at contact points A, B and C supporting two identical rollers each of weight 1000N as shown in Fig.Q.4(b) (06 Marks)

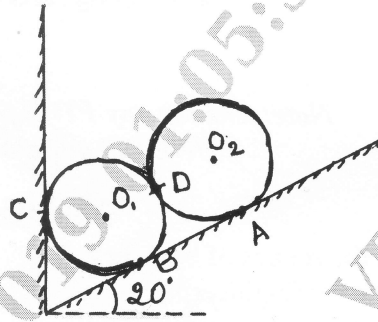

Fig.Q.4(b)

- c. A ladder 4m long and weighing 200N is placed against a vertical wall and rests on a horizontal floor making an angle 60° with the floor. The coefficient of friction between ladder and floor is 0.3 and that between ladder and wall is 0.2. The ladder in addition to its own weight supports a person weighing 600N at a distance of 3m from the floor along the ladder. Calculate the minimum force 'P' to be applied horizontally at the floor level on the ladder to keep it in equilibrium. (10 Marks)

Module-3

- 5 a. Determine the support reactions in case of a simply supported beam shown in Fig.Q.5(a). (06 Marks)

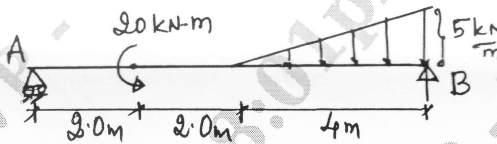

Fig.Q.5(a)

- b. Analyze the truss shown in Fig.Q5(b) to find member forces in member BC, CH and GH by method of sections. (14 Marks)

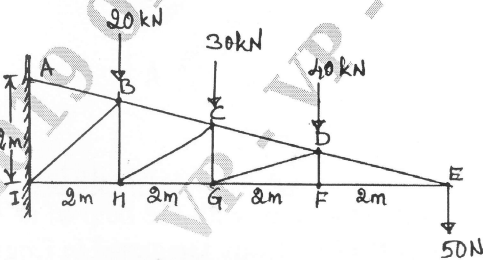

Fig.Q5(b)

OR

- 6 a. Differentiate statically determinate and indeterminate structures with examples for each. (06 Marks)
- b. Determine member forces in the truss shown in Fig.Q.6(b). (14 Marks)

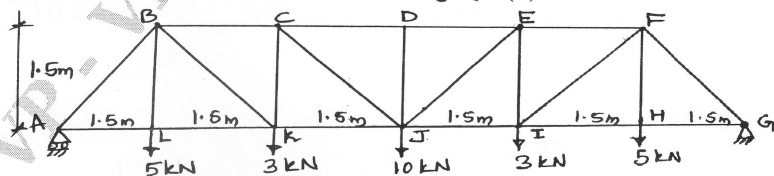

Fig.Q.6(b)

Module-4

- 7 a. Derive the expression for centroid of a semi-circle from first principle. (06 Marks)
 b. Determine the centroid of shaded area of composite shown in Fig.Q.7(b) with respect to origin 'O'. (14 Marks)

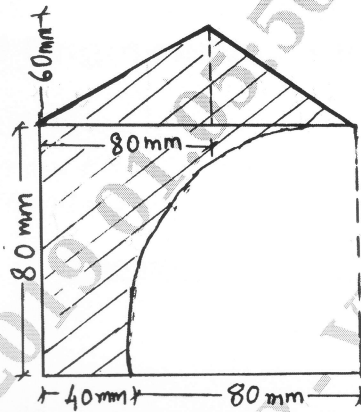

Fig.Q.7(b)

OR

- 8 a. State and prove Parallel axis theorem. (06 Marks)
 b. Find radius of gyration of plane lamina about its horizontal centroidal axis shown in Fig.Q.8(b). (14 Marks)

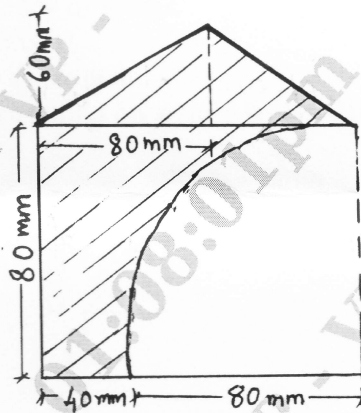

Fig.Q.8(b)

Module-5

- 9 a. Two cars P and Q accelerates from a standing start. The acceleration of P is 1.3 m/s^2 and that of Q is 1.6 m/s^2 . If Q was originally 6m behind P, how long it takes to overtake P? (10 Marks)
 b. A stone 'A' is dropped from top of a tower 50m heigh. At the same time another stone 'B' is thrown up from the foot of the tower with the velocity of 25m/s. At what distance from top and after how much time the two stones will cross each other. (10 Marks)

OR

- 10 a. State D' Alembert's principle and write significance of it structural dynamics. (06 Marks)
 b. A cricket ball is thrown by a fielder in the ground from a height of 3m at an angle of 40° with the horizontal. The velocity with which the ball is thrown is 30m/s. The ball hits the wicket at a height of 0.3m from ground. Determine the distance of the fielder from the wicket when the ball is thrown. (14 Marks)
