





COURSE LABORATORY MANUAL

A. LABORATORY OVERVIEW

Degree:	B.E	Programme:	EC
Semester:	I	Academic Year:	2020-21
Laboratory Title:	Engineering Physics Laboratory	Laboratory Code:	18PHYL16
L-T-P-S:	0-1-2-0	Duration of SEE:	3 Hrs
Total Contact Hours:	36 Hrs	SEE Marks:	60*
Credits:	1	CIE Marks:	40
Lab Manual Author:	Dr. Prasad N.Bapat		21/08/20
Checked By:	Prof. Thejaswini L. P		21/08/20

*The SEE will be conducted for 100 marks and proportionally reduced to 60 marks.

B. DESCRIPTION

1. PREREQUISITES:

- Knowledge of units and dimensions.
- Able to measure length (with vernier calipers and screw gauge), mass and time.
- Knowledge of using graph sheets (assigning scales, obtaining slope etc.) and reading the graph.
- Identifying the electronic components.
- Knowledge of using a multimeter.
- Usage of microscope and telescope.

2. BASE COURSE:

- Engineering Physics

3. COURSE OUTCOMES:

At the end of the course, the student will be able to;

1. appreciate the importance of concepts of interference of light, diffraction of light, Fermi energy and magnetic effect of current.
2. understand the principles of operations of optical fibers and; semiconductor devices such as photodiode, and NPN transistor using basic circuits.
3. determine the elastic moduli and moment of inertia of given materials with the help of suggested procedures.
4. recognize the resonance concept and its practical applications.
5. understand the importance of measurement procedures, honest recording, data representation and reproducibility of final results.

4. RESOURCES REQUIRED:

- Electrical power with single phase 5A/15A, \approx 220V and 50Hz installations fitted with plug points and switches.
- Electrical and electronic equipments such as, electrical heater, regulated power supplies, multimeters and electronic components (resistors, capacitors, diodes, transistors etc.). Traveling microscopes, spectrometer, gratings, lenses, scale, vernier calipers, screw gauges, thermometers, semiconductor laser source, shock tube, pendulum arrangement and water.

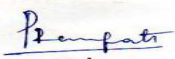

Prepared by:



Checked by:



HOD



COURSE LABORATORY MANUAL

- Dielectric constant and Photo diode experimental kits.
- Copper coil, magnet, springs, optical fiber cable, slotted weights
- Graph sheets with linear scale.
- Resource display charts

5. RELEVANCE OF THE COURSE:

- Network Theory -18EC32
- Electronic devices-18EC33
- Electronic Devices & Instrumentation Laboratory -18ECL37
- Electromagnetic waves -18EC55

6. GENERAL INSTRUCTIONS:

I Common Instructions:

- All the twelve experiments mentioned in the **VTU Syllabus – 2018** are to be conducted.
- Total experiments will be conducted in 2 cycles with predetermined numbers in each cycle.
- In a division, number of students will be divided into 2 batches. Each experiment will be performed by a team of 2-3 students.
- Students should come with observation writing book, pen, pencil, eraser, scientific calculator and scale.
- Students should come prepared by learning the theory, formula to be used, tabular parameters, circuit diagram (if any) and units.
- Students should finish the calculations and graph(s) pertaining to the experiment(s) of the day before leaving the laboratory.
- Students should come prepared for the *viva-voce* of the experiment(s) of the day.
- Observation book is evaluated based on the performance in conducting the experiment(s) and *viva-voce*.
- Students should promptly submit the written Record in the successive laboratory sessions.
- Practical internal tests will be conducted on prior notification.
VTU practical examination is conducted for 100 marks and proportionally reduced to 60 marks. Two experiments will have to be performed in 3 hrs.

II. Laboratory Instructions:

- While performing the experiments, handle the equipments with care. Any breakage should immediately be reported.
- While using the electrical equipments, such as, power supply, function generator, experimental kits and multimeters, use the knobs carefully. And while, switching OFF, keep them in minimum position and unplug.
- When an experiment is finished, if used, electronic circuits should be disconnected and, individual components and patch chords should be layed neatly on the experimental table.
- Protect yourself from the electric shock, high temperature and sharp edged objects.
- If you need graph sheets and Record pages, get it from the laboratory counter.
- Graphs should be neatly drawn with pencil. Assign appropriate scales for the obtained data. Always label the axes of the graph with proper parameters and units.

If a student misses a laboratory session, he/she should complete the experiment within a



COURSE LABORATORY MANUAL

week seeking prior permission from the laboratory staff and supervision.

7. CONTENTS:

Expt No.	Title of the Experiments	RBT	CO
Cycle-I			
1	Dielectric constant	L3	4
2	Torsional pendulum	L3	3
3	Photo diode characteristics	L3	2
4	Fermi Energy	L5	1
5	Laser diffraction	L2	1
6	Transistor characteristics	L4	2
Cycle-II			
7	Series and parallel LCR resonance	L3	4
8	Single Cantilever bending	L3	3
9	Optical fiber	L2	2
10	Magnetic field intensity(by deflection method)	L5	1
11	Spring constants	L2	3
12	Newton's rings	L2	1
Cycle-III			
13	Open ended experiment - 1		
14	Open ended experiment - 2		

8. REFERENCE:

1. A Text book of Engineering Physics- M.N. Avadhanulu and P.G. Kshirsagar, 10th revised Ed, S. Chand & Company Ltd, New Delhi
2. Engineering Physics-Gaur and Gupta-Dhanpat Rai Publications-2017
3. Concepts of Modern Physics-Arthur Beiser: 6th Ed;Tata McGraw Hill Edu Pvt Ltd- New Delhi 2006
4. Introduction to Mechanics — MK Verma: 2nd Ed, University Press(India) Pvt Ltd, Hyderabad 2009
5. Lasers and Non Linear Optics – BB laud, 3rd Ed, New Age International Publishers 2011
6. Solid State Physics-S O Pillai, 8th Ed- New Age International Publishers-2018
7. Introduction to Electrodynamics- David Griffiths: 4th Ed, Cambridge University Press 2017

C. EVALUATION SCHEME

For CBCS 2017 and 2018 scheme:

1. Laboratory Components : 30 Marks
(Record writing, Laboratory performance and Viva-voce)
2. Laboratory IA tests: 10 Marks
(Minimum 2 IAs are mandatory. For the final IA test marks, average of the 2 IA test marks shall be considered and converted to maximum of 10)
3. Continuous Internal Evaluation (CIE) = 30 + 10 = 40 Marks
4. SEE : 60* Marks



COURSE LABORATORY MANUAL

(*The SEE will be conducted for 100 marks and proportionally reduced to 60 marks)

D1. ARTICULATION MATRIX

Mapping of CO to PO

COs	POs											
	1	2	3	4	5	6	7	8	9	10	11	12
1. appreciate the importance of concepts of interference of light, diffraction of light, Fermi energy and magnetic effect of current.	2	2	1	1	-	-	-	-	1	1	-	-
2. understand the principles of operations of optical fibers and; semiconductor devices such as photodiode, and NPN transistor using basic circuits.	2	2	1	1	-	-	-	-	1	1	-	-
3. determine the elastic moduli and moment of inertia of given materials with the help of suggested procedures.	2	2	1	1	1	-	-	-	2	1	-	-
4. recognize the resonance concept and its practical applications.	2	2	1	1	-	-	-	-	1	1	-	-
5. understand the importance of measurement procedures, honest recording, data representation and reproducibility of final results.	2	1	-	-	-	-	-	2	-	-	-	-

Note: Mappings in the Tables D1 (above) and D2 (below) are done by entering in the corresponding cell the Correlation Levels in terms of numbers. For Slight (Low): 1, Moderate (Medium): 2, Substantial (High): 3 and for no correlation: “ - ”.

D2. ARTICULATION MATRIX CO v/s PSO

Mapping of CO to PSO

COs	PSOs			
	1	2	3	4
1. appreciate the importance of concepts of interference of light, diffraction of light, Fermi energy and magnetic effect of current.	-	2	-	-
2. understand the principles of operations of optical fibers and; semiconductor devices such as photodiode, and NPN transistor using basic circuits.	3	-	-	-
3. determine the elastic moduli and moment of inertia of given materials with the help of suggested procedures.	-	-	-	-



Vivekananda College of Engineering & Technology

[A Unit of Vivekananda Vidyavardhaka Sangha Puttur ®]

Affiliated to Visvesvaraya Technological University

Approved by AICTE New Delhi & Recognised by Govt of Karnataka

TCPO3

Rev 1.2

FY/PHY

21/08/20

COURSE LABORATORY MANUAL

4. recognize the resonance concept and its practical applications.	2	-	-	-
5. understand the importance of measurement procedures, honest recording, data representation and reproducibility of final results.	-	-	-	-



COURSE LABORATORY MANUAL

E. EXPERIMENTS

1. EXPERIMENT NO:1

2. TITLE: **DIELECTRIC CONSTANT**

3. LEARNING OBJECTIVES:

- To know about dielectric material
- To know about Dielectric constant
- To learn requirement of Dielectric material in the Capacitor
- To learn response of the dielectric material to the electric field
- To study the nature of charging and discharging curve of the Capacitor

4. AIM:

To determine dielectric constant of the dielectric material in the given capacitor by using RC charging and discharging circuit.

5. MATERIAL / EQUIPMENT REQUIRED:

5V DC power supply, digital voltmeter, timer, resistors of known values and capacitor with known dimensions of dielectric material within itself, circuit unit, and patch chords.

6. THEORY :

Capacitors are the devices which store electric energy by means of an electrostatic field and release this energy later. The voltage across the capacitor when gets charged gradually at any instant of time t is given by,

$$V_c = V(1 - e^{-t/RC}), \text{ where}$$

'V' is the voltage applied; 'R' is the resistance and 'C' the capacitance in the circuit.

While discharging through the resistor 'R', the capacitor voltage at any instant t is given by,

$$V_c = V e^{-t/RC}$$

Let $T_{1/2}$ be the time required to charge or discharge a capacitor to 50%.

$$\text{When } t = T_{1/2}, V_c = V/2$$

$$V/2 = V e^{-t/RC}$$

$$\Rightarrow e^{t/RC} = 2$$

$$\frac{t}{RC} = \log_e 2 = 0.693$$

$$C = T_{1/2} / 0.693 R$$

$$\text{But, } C = K \epsilon_0 A / d$$

where, 'A' and 'd' are the area and thickness of the dielectric material respectively. ϵ_0 is the permittivity of free space and 'K' the dielectric constant.

7. FORMULA / CALCULATIONS:

Measured values:

$$R = \text{_____ } \Omega$$

$$T_{1/2} = \text{_____ seconds}$$

(time in seconds required to get charged/ discharged to 50% of the capacitance value)



COURSE LABORATORY MANUAL

$$\epsilon_0 = 8.85 \times 10^{-12} \text{ F/m (data)}$$

Data on dielectric material in the capacitor:

$$\text{Length, } l = \text{_____ mm} = \text{_____ m}$$

$$\text{Breadth } b = \text{_____ mm} = \text{_____ m}$$

$$\text{Thickness } d = \text{_____ mm} = \text{_____ m}$$

Therefore area of the dielectric material,

$$A = l \times b = \text{_____} \times \text{_____} = \text{_____ m}^2$$

Therefore dielectric constant of the dielectric material is,

$$K = \frac{dT_1 \times 10^{-6}}{0.693 \epsilon_0 AR}$$

8. PROCEDURE :

1. The required circuit is shown in Fig.:1.1. The supply points are switched on.
2. The 5V power supply is connected to points A and B. The given resistor (R) is connected between the points M and N.
3. The given capacitor (C) is connected between the points S and T. To begin with, the toggle in the switch S_2 is set to halt position.
4. The timer is set to zero by pressing the reset button. The digital voltmeter (DVM) is connected between the points Q and S in the circuit, at which the time it should read zero.
5. CHARGE MODE STUDIES:-
6. The toggle switch, S_1 is set to charge mode and toggle switch, S_2 is flicked to start position SIMULTANEOUSLY. The capacitor begins to get charged to higher voltage and the timer starts counting simultaneously.
7. Immediately start noting down the voltage readings 'V' in the voltmeter at every 5 seconds interval from zeroth second, until V becomes practically constant (i.e., say, when consecutive readings remain same).
8. The readings for V are entered in the tabular column, under charge mode (the readings must be $V = 0$ for $T = 0$).

DISCHARGE MODE STUDIES:-

The following 4 operations must be performed in quick succession.

1. The toggle switch, S_1 is set to discharge mode and the timer reset button is pressed SIMULTANEOUSLY. The capacitor begins to get discharged, voltage decreases and the timer starts counting simultaneously.
2. Immediately, start noting down the reading of V at every 5 seconds interval till V becomes practically constant i.e., constant over consecutive observations.
3. The readings for V are tabulated under discharge mode (for $T = 0$, the entry for V must be



COURSE LABORATORY MANUAL

same as the maximum voltage value attained during the charge mode studies.)

EVALUATION OF UNKNOWN:-

From the tabular column readings, a graph is plotted with the time T in seconds taken along X-axis, and voltage V volts taken along Y-axis. The charge mode curve and discharge mode curve intersect at point P (Fig.: 2.2). By referring the position of 'P' to the time axis, the value of abscissa $T_{1/2}$ in seconds is found out. The value of dielectric constant K is given by,

$$K = \frac{dT_{1/2} \times 10^{-6}}{0.693\epsilon_0 AR}$$

where, 'd' and 'A', are the thickness (m) and area (m²) of the dielectric material (in SI units)

'ε₀', is the permittivity of the free space,

'R' is the resistance in the circuit (Ω)

9. CIRCUIT :

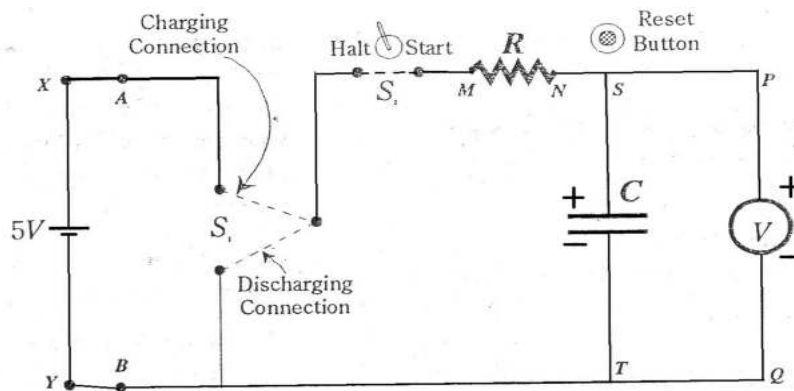

10. OBSERVATION TABLE :

Time (s) T	For R = 100 kΩ, Voltage across C (V)	
	Charge mode	Discharge mode
0		
5		
10		
15		
..		
..		
..		
..		
90		
95		



COURSE LABORATORY MANUAL

11. GRAPHS :

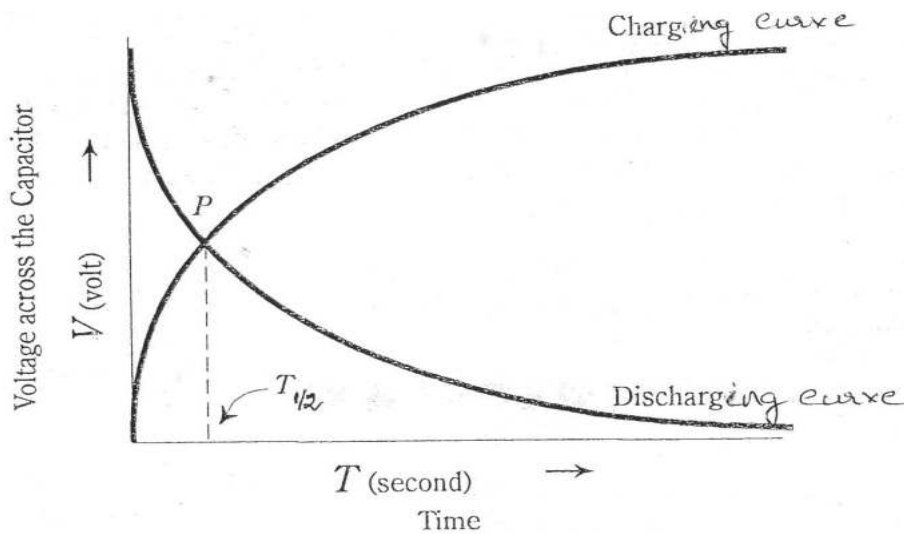

12. RESULTS & CONCLUSIONS:

- Dielectric constant of the dielectric material in the given capacitor =
- Charging and discharging curve shows a typical variation of voltage with time.

13. LEARNING OUTCOMES :

- Use of dielectrics in capacitor enhances the capacitance
- When the power is OFF, at the instance the capacitor is still accumulated with some electric charges and gradually decreasing

14. APPLICATION AREAS:

Capacitors, dielectric resonator

15. REMARKS:

To be written by the student.



COURSE LABORATORY MANUAL

1. EXPERIMENT NO:2
2. TITLE: TORSIONAL PENDULUM
3. LEARNING OBJECTIVES: To learn some of the mechanical properties of materials viz., moment of inertia and modulus of rigidity.
4. AIM: To determine the moments of inertia of irregular body and modulus of rigidity (or shear modulus) of the material of suspension wire using torsional pendulum method
5. MATERIAL / EQUIPMENT REQUIRED: Rectangular plate, Circular plate, irregular plate, stop clock, weighing machine, vernier calipers, screw gauge, suspension wire, check nut and centimeter scale
6. THEORY: <p>The period of torsional oscillation of a rigid body a wire and oscillating with small amplitude is</p> $T = 2\pi\sqrt{\frac{I}{C}}$ <p>where, I is the moment of inertia of the oscillating body about the axis of suspension and C is the couple per unit twist of the wire.</p> <p>By squaring and rearranging the above equation we will get</p> $\frac{I}{T^2} = \frac{C}{4\pi^2} = \text{a constant.}$ <p>Different values of $\frac{I}{T^2}$ are found out for the given wire using bodies of regular shape like circular and rectangular plate. Finally the irregular body is suspended and the period T_x is determined. If I_x is the moment of inertia of the irregular body</p> $\frac{I_x}{T_x^2} = \frac{I}{T^2} \quad \text{and} \quad I_x = \left[\frac{I}{T^2} \right] T_x^2$ <p>The couple per unit twist $C = \frac{\pi n r^4}{2l}$ where, r is the radius and l is the length of the wire and n is the modulus of rigidity of the material.</p> <p>On substitution $C = 4\pi^2 \left[\frac{I}{T^2} \right]$, we get $n = \frac{8\pi l}{r^4} \left[\frac{I}{T^2} \right]$</p>
7. FORMULA / CALCULATIONS: For rectangular Plate: <p>Moment of Inertia perpendicular to the Length and along the plane $I_L = \frac{M_1 L^2}{12}$ kg-m²</p> <p>Moment of Inertia perpendicular to the Breadth and along the plane $I_B = \frac{M_1 B^2}{12}$ kg-m²</p> <p>Moment of Inertia perpendicular to the Plane, $I_p = \frac{M_1(L^2 + B^2)}{12}$ kg-m²</p>



COURSE LABORATORY MANUAL

where, M₁ is the mass of the rectangular plate (in kilogram)

L is the length of the rectangular plate (in meter)

B is the breadth of the rectangular plate (in meter)

R is the radius of the circular plate (in meter)

For circular Plate:

Moment of Inertia perpendicular to the Plane, $I_R = \frac{M_2 R^2}{2}$ kg-m²

Moment of Inertia along the Diameter, $I_D = \frac{M_2 R^2}{4}$ kg-m²

where, M₂ is the mass of the circular plate (in kilogram)

R is the radius of the circular plate (in meter)

The moment of inertia of irregular body about an axis passing through the centre of gravity and

(a) Perpendicular to the plane

$$I_{px} = \frac{I}{T^2} \times T_{px}^2 \quad \text{kg-m}^2$$

(b) Along the plane (perpendicular to the Length or breadth)

$$I_{ax} = \frac{I}{T^2} \times T_{ax}^2 \quad \text{kg-m}^2$$

where, $\frac{I}{T^2}$ is the mean value of $\frac{I}{T^2}$ through different axes of the rectangular and circular plates

T_{px} is the period for one oscillation perpendicular to the plane of irregular body (in second)

T_{ax} is the period for one oscillation along the plane of irregular body (in second)

The modulus of rigidity of the suspension wire,

$$n = \frac{8\pi l}{r^4} \left[\frac{I}{T^2} \right] \quad \text{N/m}^2$$

where, l is the length of the suspension wire (in meter)

r is the radius of the suspension wire (in meter)



COURSE LABORATORY MANUAL

$\frac{I}{T^2}$ is the mean value of $\frac{I}{T^2}$ through different axes of the rectangular and circular plates

8. PROCEDURE / PROGRAMME / ACTIVITY:

1. The length L, and breadth B of the rectangular plate, the radius R of the circular plate and their respective masses are determined.
2. The given rectangular plate is suspended by a wire by a rigid support about an axis perpendicular to its length.
3. A reference point is marked on the plate. The plate is now rotated by a small angle θ about the wire and released. It executes torsional oscillations. The time for 10 oscillations and its period (T) is calculated.
4. Now, the rectangular plate is suspended perpendicular to the breadth and plane. And procedure is repeated.
5. The moment of inertia I (in Kg-m²) of the rectangular plate about its different axes are calculated using the formula, $I_L = \frac{M_1 L^2}{12}$ $I_B = \frac{M_1 B^2}{12}$

where, M₁ is the mass of the rectangular plate

6. The moment of inertia of circular plate about two axes of suspension (axis perpendicular to the plane and axis along the diameter) are calculated using the formula, $I_R = \frac{M_2 R^2}{2}$;

$$I_D = \frac{M_2 R^2}{4}$$

IN EACH CASE I/T² IS CALCULATED AND MEAN VALUE IS FOUND.

To find the moment of inertia of irregular body :

1. The irregular body is now suspended perpendicular to the plane and along the plane and its period of oscillation, T_{px} and T_{ax} are found out.
2. The moment of inertia of the irregular body is calculated using the formula

$$I_{px} = \frac{I}{T^2} \times T_{px}^2 \quad \text{and} \quad I_{ax} = \frac{I}{T^2} \times T_{ax}^2 \text{ Kgm}^2$$

COURSE LABORATORY MANUAL

To determine the rigidity modulus of the material of the suspension wire

1. The length l and radius r of the suspension wire are determined using vernier calipers and screw guage respectively.
2. The rigidity modulus of the suspension wire is calculated using the formula

$$n = \frac{8\pi l}{r^4} \left(\frac{I}{T^2} \right) N/m^2$$

9. BLOCK / CIRCUIT / MODEL DIAGRAM / REACTION EQUATION:

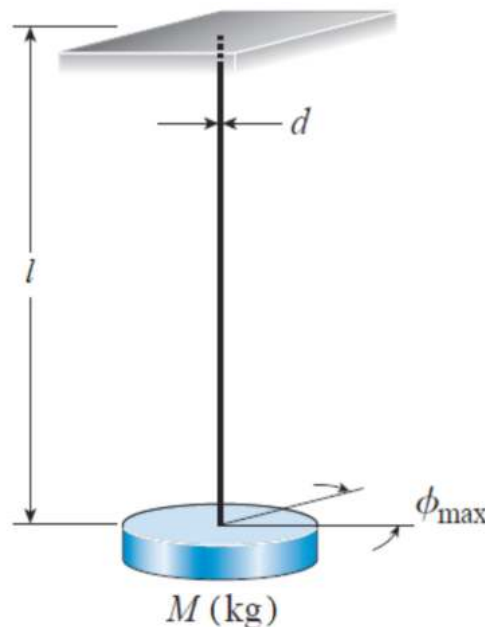

Fig.9.1: Schematic representation of torsion pendulum.

10. OBSERVATION TABLE / LOOKUP TABLE / TRUTH TABLE:

Mass of the rectangular plate, $M_1 = \underline{\hspace{2cm}}$ kg

Mass of the circular plate, $M_2 = \underline{\hspace{2cm}}$ kg

Length of the rectangular plate, $L = \underline{\hspace{2cm}}$ m

Breadth of the rectangular plate, $B = \underline{\hspace{2cm}}$ m

Diameter of the circular plate, $D = \underline{\hspace{2cm}}$ m

Radius of the circular plate, $R = D/2 = \underline{\hspace{2cm}}$ m

For rectangular Plate:

Moment of Inertia perpendicular to the Length and along the plane, $I_L = \frac{M_1 L^2}{12} = \dots\dots\dots \text{kgm}^2$



COURSE LABORATORY MANUAL

Moment of Inertia perpendicular to the Breadth and along the plane, $I_B = \frac{M_1 B^2}{12} = \dots\dots \text{kgm}^2$

Moment of Inertia perpendicular to the Plane, $I_p = \frac{M_1(L^2 + B^2)}{12} = \dots\dots \text{kgm}^2$

For circular Plate:

Moment of Inertia perpendicular to the Plane, $I_R = \frac{M_2 R^2}{2} = \dots\dots \text{kgm}^2$

MOMENT OF INERTIA ALONG THE DIAMETER, $I_D = \frac{M_2 R^2}{4} = \dots\dots \text{kgm}^2$

To find $\frac{I}{T^2}$:

Shape	Axis of suspension	MI, (kg-m ²)	Time for 10 Oscillations (s)			Period, T (s)	$\frac{I}{T^2}$ Kg-m ² /s ²
			1	2	Mean		
Rectangular plate	Perpendicular to length and along the plane	$I_L =$					
	Perpendicular breadth and along the plane	$I_B =$					
	Perpendicular to plane	$I_p =$					
Circular disc	Perpendicular to plane	$I_R =$					
	Along the diameter	$I_D =$					

Mean $\frac{I}{T^2} = \dots\dots \text{kg-m}^2/\text{s}^2$



COURSE LABORATORY MANUAL

To find moment of inertia of the Irregular Body:

Period of oscillation (T_x) of irregular body.

Table with 4 columns: Axis of suspension, Time for 10 oscillations (s) (subdivided into 1, 2, Mean), and Period T(s). Rows include 'Perpendicular to the plane' and 'Along the plane (perpendicular to the Length or breadth)'.

THE MOMENT OF INERTIA OF IRREGULAR BODY ABOUT AN AXIS PASSING THROUGH THE CENTRE OF GRAVITY AND

(a) Perpendicular to the plane

I_px = (I / T^2) * T_px^2 = kgm^2

(b) Along the plane (perpendicular to the Length or breadth)

I_ax = (I / T^2) * T_ax^2 = kgm^2

To find the modulus of rigidity of the suspension wire:

Length of the suspension wire, l = _____ cm = _____ m

Radius of the wire, r = _____ m

The modulus of rigidity of the suspension wire,

n = (8*pi / r^4) * [I / T^2]

= GPa



COURSE LABORATORY MANUAL

11. GRAPHS / OUTPUTS: Values of the moment of inertia for the different shaped objects and modulus of rigidity of the suspension wire.

12. RESULTS & CONCLUSIONS:

(1) The moments of inertia of irregular body about an axis passing through centre of gravity and

(a) Perpendicular to the plane = _____ kg-m²

(b) Parallel (along) to the plane = _____ - kg-m²

(2) Rigidity modulus of the suspension wire material = _____ GPa or kN/mm²

13. LEARNING OUTCOMES : Moments of inertia of a irregular body is estimated by adopting the torsional property of the steel wire. Also, the modulus of rigidity of the suspension steel wire has been determined and found to be in agreement with the material data book.

14. APPLICATION AREAS: In civil engineering constructions and designing machinery

15. REMARKS:



COURSE LABORATORY MANUAL

1. EXPERIMENT NO.: 3

2. TITLE: **PHOTODIODE CHARACTERISTICS**

3. LEARNING OBJECTIVES:

- (i) To show that as the intensity of light falling on a photodiode increases, the current through it also increases.
- (ii) To estimate the quantum efficiency of the given photo diode.

4. AIM:

To determine the power responsivity, quantum efficiency and study the I-V characteristic of photodiode.

5. EQUIPMENTS REQUIRED:

Power supply, ammeter, voltmeter, photodiode and white LED.

6. THEORY:

Photodiode is a two terminal junction diode which operates in reverse bias. It has a metal body with a small transparent window through which light enter inside the photodiode and strikes the PN junction, A junction has very small reverse current (of the order μA) when it is reverse biased. The same reverse current exists for photodiode but it differs from the junction diode because reverse current changes with illumination of light and it behaves like a current source. When there is no illumination reverse current is almost negligible (called dark current). Reverse current increases when light intensity decreases.

When it is operated without bias, the current is distributed between the shunt resistance and external load resistor. Now a voltage is developed which creates forward bias, thus reducing its ability to remain as a constant current sources. When operated with bias, the photodiode becomes ideal current sources.

It can be used as device controlled by light intensity, high speed switching circuit, photo detection and demodulation, as a switch in optical communication system.

Optical Characteristics:

Responsivity (R_λ)

The responsivity of a silicon photodiode is the measure of its sensitivity to light, and it is defined as the ratio of the photodiode current I_{PD} to the incident LED power P_{LED} at a given wavelength.

$$R_\lambda = \frac{I_{PD}}{P_{LED}} \dots\dots\dots(1)$$

where, I_{PD} is photodiode current and P_{LED} is the light input power.

In otherwords, it is a measure of the effectiveness of the conversion of light as well as applied reverse electrical current. It varies with the wavelength of the incident light as well as applied reverse bias and temperature. By drawing graph of I_{PD} versus P_{LED} and finding the slope of the straight line gives, Responsivity. Responsivity increases slightly with applied reverse bias due to improved charges collection efficiency in photodiode. Also, there are responsivity variations due to change in temperature. This is due to decrease or increase of the band gap, because of increases or decreases in temperature respectively.



COURSE LABORATORY MANUAL

QUANTUM EFFICIENCY:

Quantum efficiency is the ratio of number of charge carriers produced by the photodiode to the number of photons falling on the photodiode.

Q.E = (charge carriers/second) / (photons/second) = (current/charge of one electron) / (total power/energy of one photon)

Q.E = (I/e) / (P/E) = IE / eP

Q.E = (Ihc) / (Pλe) since E = hc/λ

Q.E = Rλ (hc/λe) Where Rλ = I/P

Q.E = (Rλ × 6.636 × 10^-34 × 3 × 10^8) / (λ × 1.602 × 10^-19)

Q.E = (Rλ × 1240 × 10^-9) / λ

I-V Characteristics:

The current-voltage (I-V) characteristic of a photodiode with no incident light is similar to that of a rectifying diode. When the photodiode is forward biased, there is an exponential increases in the current. When a reverse bias is applied, a small saturation current appears. It is related to dark current as -

ID = Isat (e^(eV/kT) - 1).....(2)

This is purely the diode current. Illuminations junction by a light source produce a current given by equation (1). Hence the total current we measure in series with photodiode.

ID = Isat (e^(eV/kT) - 1) - Ip.....(3)

As the applied reverse bias increases, there is a sharp increase in the photo current and device will be spoiled permanently. This voltage is called, 'breakdown voltage'. Breakdown voltage varies from type to type. Hence one should not apply too much reverse bias.

7. FORMULA(E) / CALCULATIONS:

Slope = (AB × Y scale) / (BC × X scale) A/W

The external conversation efficiency of white LED is 0.66 hence dividing responsivity by 0.66 gives exact responsivity of PD



COURSE LABORATORY MANUAL

$$\text{Responsivity, } R_{\lambda} = \frac{\text{Slope}}{0.66} = \dots\dots\dots A/W$$

$$\text{Quantum efficiency, } Q.E = \frac{R_{\lambda} \times 1240 \times 10^{-9}}{\lambda}$$

$$\begin{aligned} \% \text{ Quantum Efficiency} &= Q.E \times 100 \\ &= \underline{\hspace{2cm}} \end{aligned}$$

8. PROCEDURE:

Part A : Responsivity

1. The LED (white light) and photodiode (PD) are placed face to face in the supplied experimental set-up and the light arrangement is switched ON. LED power is set to 10mW by positioning the knob to its minimum position. After confirming that the LED is glowing and PD current in the meter, the cover is placed so that external light will not affect the readings. Positive of the PD (P) is connected negative of the power supply and negative of the PD is connected positive of the power supply. This reverse biases the photodiode.
2. The voltage across PD is set to – 1V by varying power supply. The PD current I_{PD} is noted.
3. Trial is repeated for LED input power 11,12,13 mW etc. up to 50 mW. In each case V_{PD} is set to – 1V and I_{PD} is noted.
4. Draw the graph showing the variation of LED power P_{LED} on X- axis and PD current I_{PD} on y- axis as shown in Fig. 12.3. A straight line is obtained, slope of which gives 'responsivity'.
5. The external conversation efficiency of while LED is 0.66, hence by dividing responsivity by 0.66 gives the exact Responsivity of PD and quantum responsivity.

Part B : I-V Characteristic of PD

1. The LED power is set to 10mW on the dial and V_{Pd} is set to -0.10V and the I_{Pd} is noted.
2. Trial is repeated by increasing V_{Pd} in suitable steps up to maximum of 2V. The corresponding I_{Pd} is noted.
3. Experiment is repeated for by increasing the LED power to 21 and 30 mW. In each case variation in V_{Pd} and corresponding I_{Pd} are noted.
4. Draw a graph taking V_{Pd} along X-axis and I_{Pd} along Y-axis in the 3rd quadrant as shown in Fig. 12.4.

Note: When the electrical power is supplied to LED, it glows and the intensity of light increases with increasing power.

COURSE LABORATORY MANUAL

9. CIRCUIT DIAGRAM:

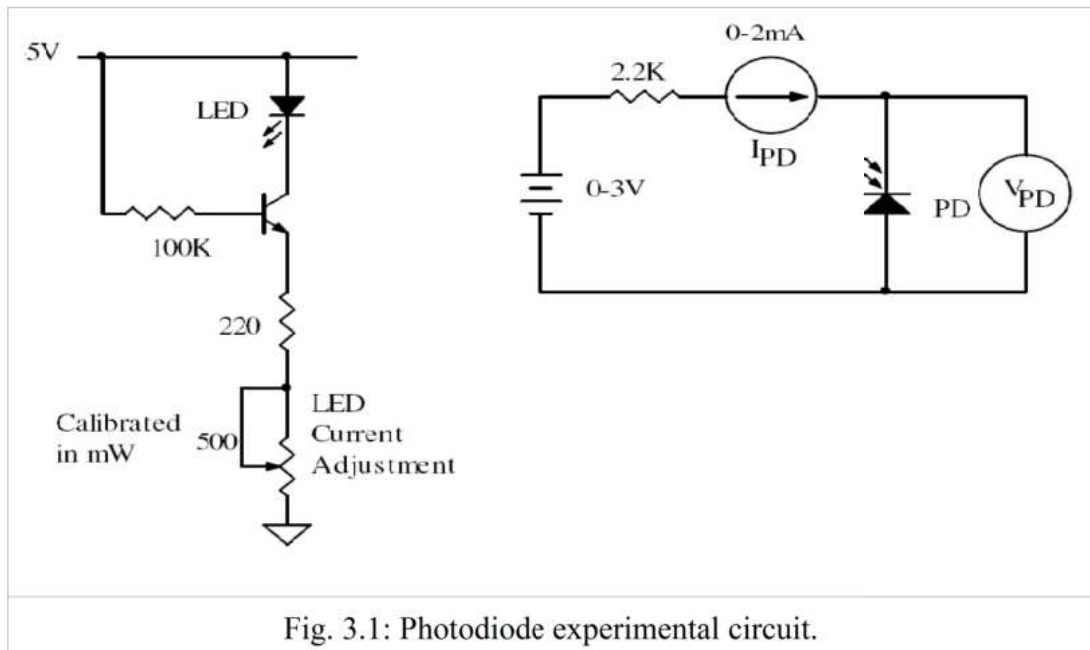

Fig. 3.1: Photodiode experimental circuit.

10. OBSERVATION TABLE:

Part A: To determine the responsivity by keeping V_{pd} to -1V for each trail

P_{LED} (mW)	I_{pd} (μA)
10	
11	
12	
13	
14	
15	
18	
21	



COURSE LABORATORY MANUAL

Part B: I-V Characteristic of PD

$V_{PD} (V)$	$I_{pd} (\mu A)$		
	$P_{LED} = 10mW$	$P_{LED} = 21mW$	$P_{LED} = 30mW$
0			
-0.1			
-0.2			
-0.3			
-0.4			
-0.5			
-0.6			
-0.7			
-0.8			
-0.9			
-1.0			
-1.5			
-2.0			

11. GRAPHS / OUPUTS:

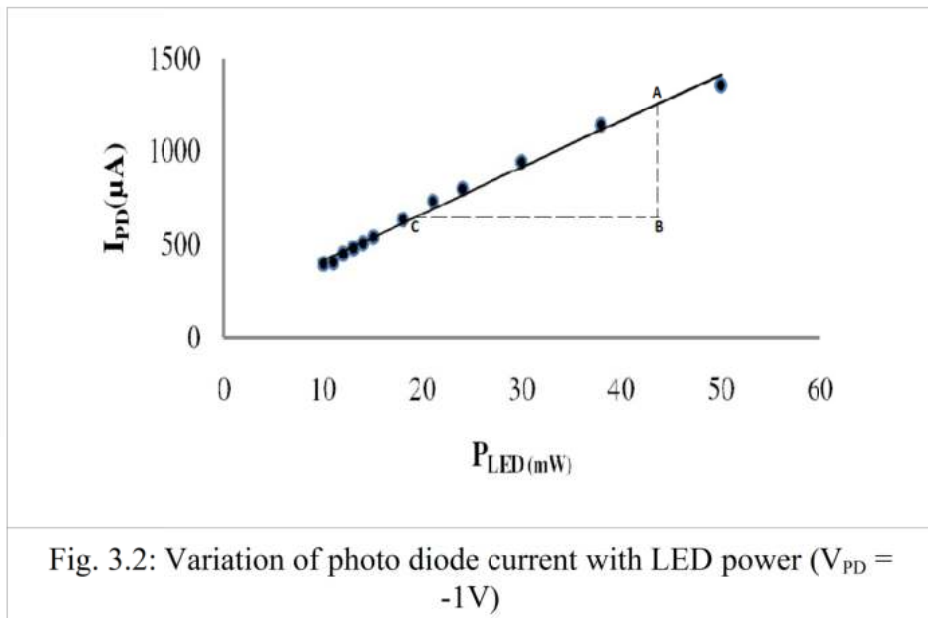



COURSE LABORATORY MANUAL

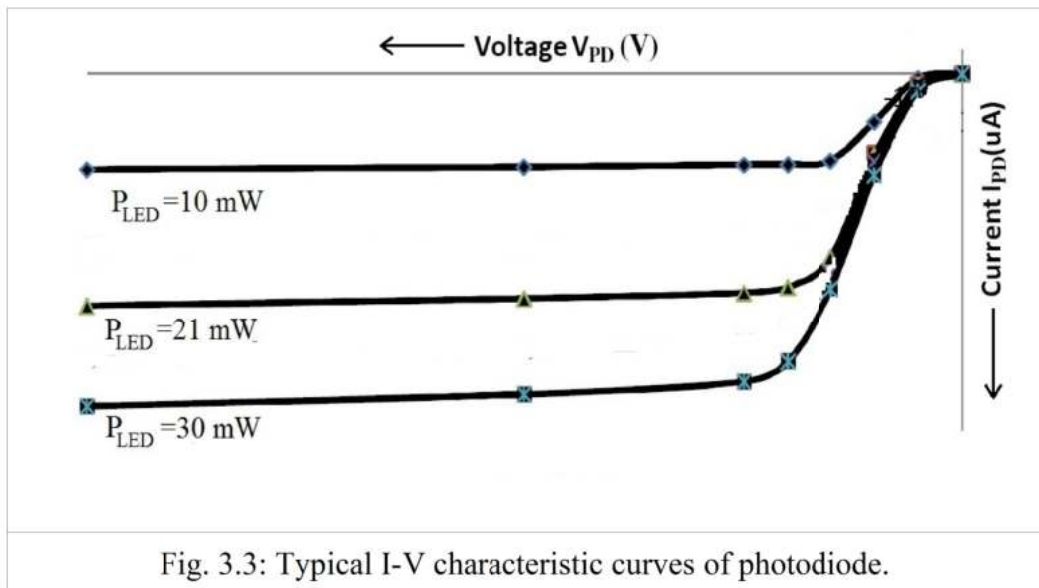

12. RESULTS & CONCLUSIONS:

1. The standard value of Responsivity is $< 0.1 \text{ A/W}$
2. The experimental value of Responsivity is $R_\lambda = \dots\dots\dots \text{A/W}$
3. % Quantum Efficiency = $\dots\dots\dots$
4. The characteristics of photodiode is studied.

13. LEARNING OUTCOMES:

- As the light intensity increased, the current in PD also increases, because of the decreased resistance.

14. APPLICATION AREAS:

- photo conductors, charge-coupled devices, and photomultiplier tubes.
- consumer electronics devices such as compact disc players, smoke detectors, and the receivers for infrared remote control devices used to control equipment from televisions to air conditioners.
- light sensors in camera. photo detectors

15. REMARKS:

To be written by the student.



COURSE LABORATORY MANUAL

1. EXPERIMENT NO.: 4

2. TITLE: **DETERMINATION OF FERMI ENERGY OF COPPER**

3. LEARNING OBJECTIVES:

- (i) To check the Ohm's law ($V=RI$).
- (ii) To know about the temperature dependence of resistance of a metallic material.
- (iii) To estimate the Fermi energy of the given material.

4. AIM:

To determine the Fermi energy of copper by studying its temperature dependence of resistance.

5. MATERIAL / EQUIPMENT REQUIRED:

Copper coil, DC regulated power supply, milli-ammeter, milli voltmeter and heating arrangement.

6. THEORY:

In metals, Fermi energy gives us information about the velocities of the electrons which participate in ordinary electrical conduction. The Fermi velocity V_F of these conduction electrons can be calculated from the Fermi energy E_F using the relation,

$$V_F = \sqrt{\frac{2E_F}{m}} \quad \dots\dots\dots 1$$

where, m is the mass of electron = 9.1×10^{-31} kg, E_F is Fermi energy and V_F is Fermi velocity. This speed is a part of the microscopic Ohm's Law for electrical conduction. A Fermi gas is a collection of non-interacting fermions. It is quantum mechanical version of ideal gas. Electrons in metals and semiconductors can be approximately considered as Fermi gases.

The number of free electrons in metal per unit volume is given by,

$$n = \frac{N\rho}{M} \quad \dots\dots\dots 2$$

where, N is Avogadro number = 6.023×10^{26} per kg mol

ρ = density of the metal (kg/m^3)

M = Atomic weight

The electrical conductivity of the metal,

$$\sigma = \frac{L}{Ra} \quad \dots\dots\dots 3$$

where, L is the length of the metal wire

R is its resistance at a reference temperature

a is the area of cross-section of the wire.

The relaxation time is given by,

$$\tau = \frac{\sigma \cdot m}{ne^2} \quad \dots\dots\dots 4$$

where, e is electron charge = 1.602×10^{-19} C

If V_F is Fermi velocity, then mean free path of electrons,

$$\lambda_F = V_F \tau \quad \dots\dots\dots 5$$



COURSE LABORATORY MANUAL

Now Fermi energy,

$$E_F = \left[\frac{ne^2 \pi Ar^2}{L\sqrt{2m}} \right] \times \left(\frac{\Delta R}{\Delta T} \right)^2 \dots\dots\dots 6$$

where, the constant, $A = \lambda_F \times T$, and n is no.of electrons per unit volume

T is the reference temperature of the wire in kelvin, and L is length of the wire (m)

r is the radius of the wire (m)

m is the mass of the electron (kg)

e is the charge of the electron (C)

$\frac{\Delta R}{\Delta T}$ is the slope of the straight line obtained from the graph of Resistance v/s Temperature

7. FORMULA(E) / CALCULATIONS:

We have the equation (6), $E_F = \left[\frac{ne^2 \pi Ar^2}{L\sqrt{2m}} \right] \times \left(\frac{\Delta R}{\Delta T} \right)^2$

In the laboratory, for the given Copper wire, L = 4m, r = 0.25x10⁻³mm

Substituting these values, we get $\left[\frac{ne^2 \pi Ar^2}{L\sqrt{2m}} \right] = 59.058 \times 10^{-14} \text{ J (K/ohm)}^2$

Therefore, Fermi energy, $E_F = 59.058 \times 10^{-14} \times (\text{slope})^2 \text{ J} \dots\dots\dots 7$

8. PROCEDURE:

1. Circuit connections are made as shown in Fig. 11.2.
2. Ensure that a thermometer is kept in side the boiling tube besides the copper coil. This set up is immersed in the beaker.
3. Heating coil is immersed in the beaker filled with water.
4. Switch ON the power supply unit and a constant current is set (~ 45mA).
5. Note the current and voltage values at room temperature (RT).
6. Switch ON the heating coil and wait until the temperature reaches around 97°C. And, switch OFF the heating coil.
7. As the temperature is decreasing, voltage and current values can be taken from 95 to 50°C in steps of 5 degrees.
8. A graph of resistance v/s temperature is drawn as shown in Fig. 11.3. The slope of the graph is determined.
9. Finally, by using equation 7 Fermi energy of the given materials are calculated.

COURSE LABORATORY MANUAL

9. CIRCUIT DIAGRAM:

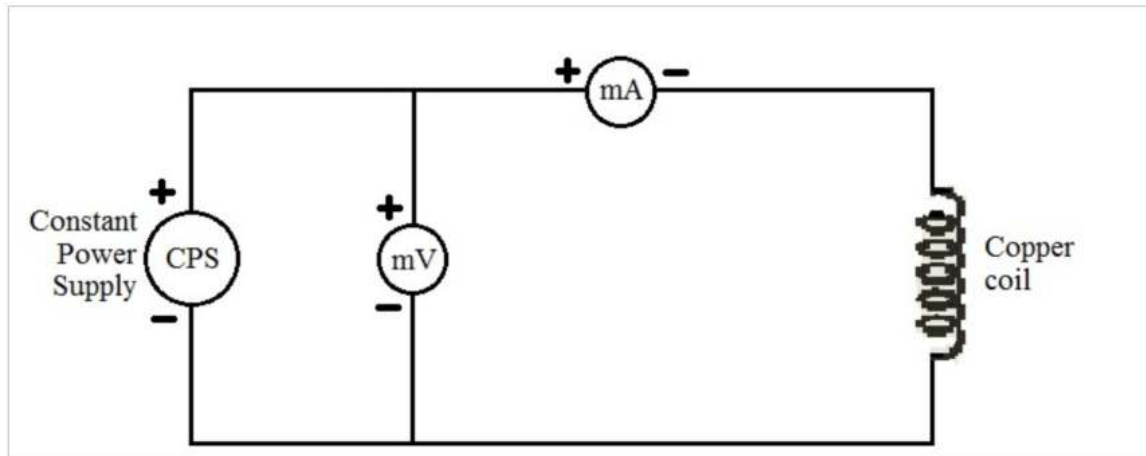

Fig. 4.1: Circuit diagram for the Fermi energy experiment.

10. OBSERVATION TABLE:

Temperature		Voltage (mV)	Current (mA)	Resistance (ohm)
(°C)	(K)			
(Room Temp.)				
95				
90				
..				
..				
..				
55				
50				

11. GRAPH:

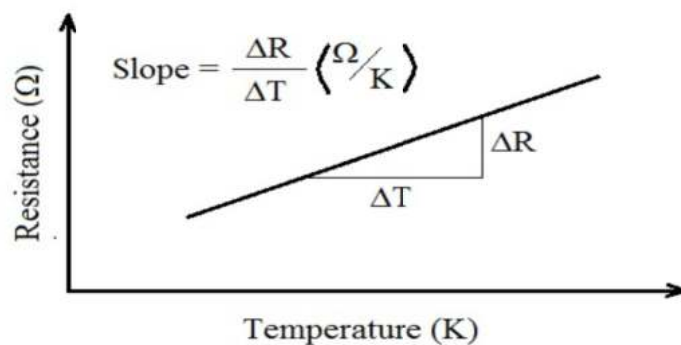

Fig. 4.2: Graphical representation of variation of resistance with temperature.



COURSE LABORATORY MANUAL

12. RESULTS & CONCLUSIONS:

The Fermi energy of the given copper material = _____ Joules.
= _____ eV

13. LEARNING OUTCOMES:

By this experiment,

- (i) Ohm's law ($V=RI$) is verified.
- (ii) Resistance of the copper coil is found to be increased with increasing temperature.
- (iii) The calculated value of Fermi energy of copper is in agreement with the referred data.

14. APPLICATION AREAS:

- To know the direction of charge flow in the junction electronic devices.
- To estimate the temperature dependence of resistivity of a material.

15. REMARKS:

To be written by the student.



COURSE LABORATORY MANUAL

1. EXPERIMENT NO.: 5

2. TITLE: **LASER DIFFRACTION**

3. LEARNING OBJECTIVES:

The objective is to (a) verify the wave nature of light by measuring its wavelength, (b) learn about diffraction of light & diffraction grating and (c) measure the wavelength of red colored Laser.

4. AIM:

To measure the wavelength of semiconductor using laser diffraction by calculating grating constant

5. MATERIAL / EQUIPMENT REQUIRED:

Laser source ($\lambda = 650\text{nm} \pm 10$; Max. O/P power = 5mW), diffraction grating (15,000 lines per inch), image screen, scale, pencil and graph sheet.

6. THEORY:

A laser consists of single wavelength falling on a grating will produce diffraction pattern. The principal maximum intensity of the diffracted light is given by

$$d \sin \theta = m \lambda \quad \dots\dots\dots (1)$$

where, 'd' is grating constant or the distance between two consecutive rulings

' θ ' is the angle of diffraction

'm' = 1, 2, 3... m is called order of diffraction

' λ ' is the wavelength of the light used

In the above equation all the terms are constant, except θ . The angle θ can be measured by experiment either using spectrometer or by measuring accurately the distance between source and image and distance between the consecutive maximums. Different order of diffraction is the result of different incident angle θ . Hence to specify order θ has been rewritten as θ_m , which indicate the diffraction angle for m^{th} order. Fig. 8.2 indicates process of diffraction, using laser light and grating. The m^{th} order diffraction angle is given by

$$\theta_m = \tan^{-1} \left(\frac{X_m}{f} \right) \quad \dots\dots\dots (2)$$

where, ' x_m ' is the distance of m^{th} order diffraction pattern from the centre 0^{th} order diffraction ' f ' is the distance between the screen and the grating. The distance ' f ' between the grating and the image screen is our choice which can be fixed as required and the distance ' x_m ' can be measured accurately from the diffraction pattern. Hence, angle of diffraction ' θ_m ' can be determined using the above equation.

Substituting ' θ_m ' in Equation-1, wavelength of the given Laser source can be determined.

That is,

$$\lambda = \frac{d \sin \theta_m}{m} \quad \dots\dots\dots (3)$$

7. FORMULA(E) / CALCULATIONS:

In the above table, from the values obtained, angle θ_m can be calculated as follows:

$$\theta_m = \tan^{-1} \left(\frac{X_m}{f} \right) \quad \text{where, } m = 1 \text{ or } 2, \text{ the order of diffraction.}$$

For the given grating, there are 15,000 slits per inch (2.542 cm). Therefore, the grating constant, ' d ' is given by,

$$d = \frac{0.02542}{15000} = 1.693 \times 10^{-6} \text{ m}$$

That is, $d = 1.693 \mu\text{m}$



COURSE LABORATORY MANUAL

Substituting 'm', 'd' and ' θ_m ' in the above Equation-1, wavelength of the given Laser source can be determined.

$$\text{That is, } \lambda = \frac{d \sin \theta_m}{m} \text{ nm}$$

Marked wavelength value of the given Laser source = _____ nm

Hence, the percentage error = [(Marked value – Determined value) x 100] / Marked value
= \pm _____ %

8. PROCEDURE:

1. Fix the Laser pointer on a firm stand and place the diffraction grating with a support such that the Laser beam falls perpendicularly on the plane of the grating as shown Fig. 5.1.
2. On the other side of the grating, keep the image screen with a graph sheet affixed on it. Make sure that the planes of grating and image screens are parallel to each other. Switch ON the Laser pointer.
3. Adjust the distance between the Laser source and grating and, grating and image screen (f) such that atleast two bright diffraction spots appear on either side of the central spot in the graph sheet.
4. Note down ' f ' in centimeters. In the graph sheet over the image screen, mark the spots $m = 1$ and 2 on either sides of the central spot (0^{th} order spot) as shown in Fig. 5.2 corresponding to the 1^{st} and 2^{nd} order diffractions, respectively.
5. Measure $2X_1$ and $2X_2$. Now, vary the distance between the grating and image screen (f) and, again measure $2X_1$ and $2X_2$.
6. The diffraction angles θ_1 and θ_2 can be calculated from the above measured values as follows:

$$\theta_m = \tan^{-1} \left(\frac{X_m}{f} \right) \text{ where, } m = 1 \text{ or } 2, \text{ the order of diffraction.}$$

7. Substituting ' θ_m ' in the above Equation-1, wavelength of the given Laser source can be determined.

$$\text{That is, } \lambda = \frac{d \sin \theta_m}{m}$$

COURSE LABORATORY MANUAL

9. BLOCK DIAGRAM:

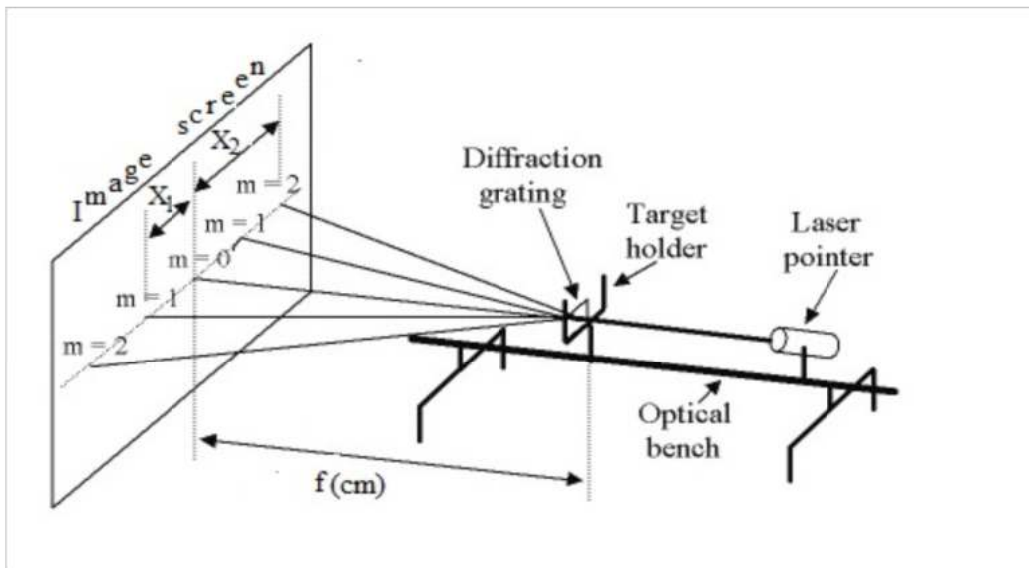

Fig. 5.1: Experimental arrangement for Laser diffraction through the grating.

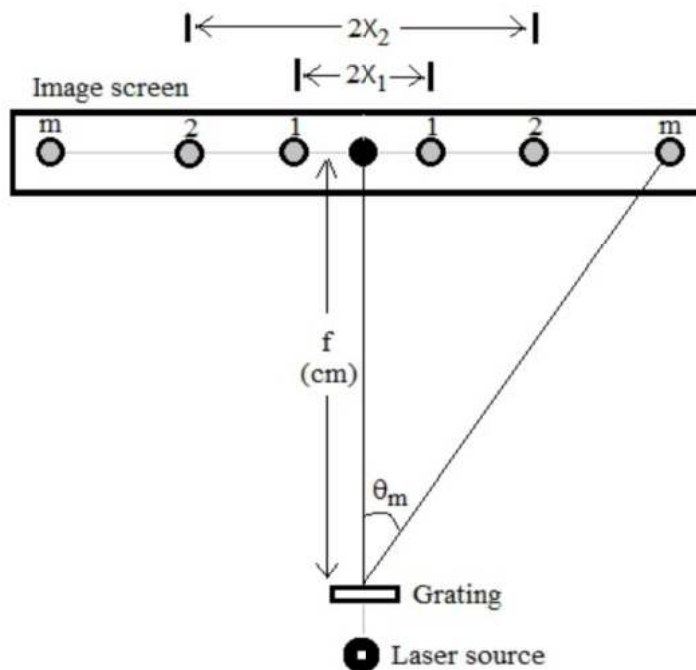

Fig. 5.2: Diffraction spot pattern and measurements.



COURSE LABORATORY MANUAL

10. OBSERVATION TABLE:

Distance between the image screen and grating, f (cm)	Diffraction order, m	Distance, $2X_m$ (cm)	Distance, X_m (cm)	Diffraction angle, θ_m ($^\circ$) $\theta_m = \tan^{-1}\left(\frac{X_m}{f}\right)$	Wavelength, λ (m) $\lambda = \frac{d \sin \theta_m}{m}$
$f_1 = 4$	1				
	2				
$f_2 = 6$	1				
	2				

Mean wavelength = _____ m
= _____ nm

11. OUPUTS:

(i) Diffraction pattern for the Laser is observed.

(ii) As the distance between the image screen and grating increases, the spacing between the diffraction spots formed for a particular diffraction order also increases.

12. RESULTS & CONCLUSIONS:

1. Wavelength of the given Laser = _____ nm

2. The wavelength calculated is in good agreement with the marked value, within the error limits of \pm _____%.

13. LEARNING OUTCOMES:

- The diffraction angle remained the same for given grating irrespective of the distance between grating and screen.

14. APPLICATION AREAS:

- Unknown wavelength of the Laser source.
- Laser diffraction method can be used to measure the size of the particle.

15. REMARKS:

To be written by the student.



COURSE LABORATORY MANUAL

1. EXPERIMENT NO.: 6

2. TITLE: **CHARACTERISTICS OF TRANSISTOR**

3. LEARNING OBJECTIVES:

- To study the nature of the input and output characteristic of a NPN transistor.
- To study the biasing and operation of the NPN transistor.
- To know the variation of knee voltage of E-B junction for different CE voltage.
- To know the variation of the saturation collector current for different base current I_B .
- To study the function of transistor of as an amplifier.

4. AIM:

To draw the input and the output characteristics of the given NPN transistor, and hence to determine its input resistance, output resistance, knee voltage, α and amplification factor (β).

5. MATERIAL / EQUIPMENT REQUIRED:

Transistor SL 100, DC dual regulated power supplies in the ranges 0 – 5V and 0 – 20V, DC - micro-ammeter (0 - 1000 μ A), DC milli-ammeter (0 – 100mA), digital voltmeter (DVM), circuit unit with a base resistor of 10k Ω , and patch chords.

6. THEORY:

A transistor is a semiconductor device. This consists of three terminals, Emitter – Base – Collector and is regarded as two diodes joined back to back. The emitter base junction is forward biased and hence the junction resistance is less. The collector base junction is reverse biased and hence the junction resistance is large. The base region is lightly doped and made very thin. The doping level in the emitter is more than the collector. At the base of the NPN transistor, the electrons coming from the emitter are attracted by the reverse biased collector. The collector current I_C is slightly less than the emitter current I_E . Due to recombination of electrons at the base, a small base current I_B is also flows in the base. Always $I_E = I_C + I_B$. Common emitter configuration is more useful than of the three types of configurations and the circuit diagram is shown in the figure. There are two current gains, $\alpha = \frac{I_C}{I_E}$ and $\beta = \frac{I_C}{I_B}$, where β is base current amplification factor & α is emitter current or simply known as amplification factor,

$$\beta = \frac{\alpha}{1 - \alpha} \quad \text{and} \quad \alpha = \frac{\beta}{1 + \beta} .$$

In this common -emitter configuration a phase shift of 180° exists between the input and the output signals

7. FORMULA(E) / CALCULATIONS:

FORMULA USED:

1. Input resistance, $R_i = \frac{\Delta V_{BE}}{\Delta I_B} = \frac{1}{\text{slope}} \Omega$, where, ΔV_{BE} is the small change in base-emitter voltage (V) and ΔI_B is the small change in base current(μ A).



COURSE LABORATORY MANUAL

2. Output resistance, $R_o = \frac{\Delta V_{CE}}{\Delta I_C} = \frac{1}{\text{slope}} \Omega$ where, ΔV_{CE} is the small change in collector emitter

voltage(V) and ΔI_C is the small change in collector current(mA).

$$3. \quad \beta = \frac{\Delta I_C}{\Delta I_B} = \frac{I_{C2} - I_{C1}}{I_{B2} - I_{B1}}$$

where, β , is the current amplification factor,

$\Delta I_B = I_{B2} - I_{B1}$, is the change in base current (μA)

$\Delta I_C = I_{C2} - I_{C1}$, is the corresponding change in collector current (mA)

$$4. \quad \alpha = \frac{\beta}{1 + \beta}$$

CALCULATIONS:

1. Evaluation of input resistance (R_i)

$$\text{Slope of the graph - I (Fig. 6.2(a))} = \frac{\Delta I_B}{\Delta V_{BE}} = \text{_____ } \mu A/V$$

$$\text{Therefore, input resistance, } R_i = \frac{1}{\text{slope}} = \text{_____ } \Omega$$

2. Evaluation of output resistance (R_o)

$$\text{Slope of the graph - II (Fig. 6.2(b))} = \frac{\Delta I_C}{\Delta V_{CE}} = \text{_____ } mA/V$$

$$\text{Therefore, output resistance, } R_o = \frac{1}{\text{slope}} = \text{_____ } \Omega$$

3. Evaluation of current amplification factor β :

From graph - II,

$$I_{C1} = \text{_____ } mA, I_{C2} = \text{_____ } mA, I_{C3} = \text{_____ } mA \text{ and}$$

$$I_{B1} = \text{_____ } \mu A, I_{B2} = \text{_____ } \mu A, I_{B3} = \text{_____ } \mu A.$$

$$\beta_1 = \frac{I_{C2} - I_{C1}}{I_{B2} - I_{B1}} =$$

$$\beta_2 = \frac{I_{C3} - I_{C2}}{I_{B3} - I_{B2}} =$$



COURSE LABORATORY MANUAL

$$\beta_3 = \frac{I_{C3} - I_{C1}}{I_{B3} - I_{B1}} =$$

The average value of $\beta = \frac{\beta_1 + \beta_2 + \beta_3}{3} =$ _____

4. Evaluation of α : $\alpha = \frac{\beta}{1 + \beta} =$ _____

8. PROCEDURE:

1. Identify the base, collector and emitter leads to the given NPN transistor and then insert it into the relemate connector (the transistor socket), in the circuit through relamate connector, the emitter, the base, and the collector get connected to the points E, B and C, respectively.
2. The biasing voltage V_{BB} and V_{CC} are applied to the circuit by connecting P to A and Q to D, in the input side, and by connecting T to F and S to G on the output side .
3. The microammeter is connected between U and V., and the milli-ammeter is connected between M & N.
3. The voltmeter (DVM) is connected between K and L.

INPUT CHARACTERSITCS STUDY:

1. All the power supply knobs are turned to the minimum position, and all power supply points are switched ON.
2. The collector emitter voltage V_{CE} is set to 1V, by varying V_{CC} .
3. The base emitter voltage is increased from 0V, in steps of 0.1 up to 1V, and the corresponding values of the base current I_B are noted from micro ammeter (μA), and entered in the tabular col-I.

EVALUATION OF THE CONSTANTS:

1. The readings are plotted, with V_{BE} along X- axis, I_B along Y- axis (Fig. 6.2(a)).
2. Portion of the curve which could be approximated to a straight line ,is extrapolated downward to meat X-axis at K and the value of V_{BE} at K , known as the knee voltage, V_{knee} is noted.
3. Input resistance is calculated using following formulae. Input resistance, $R_i = \frac{\Delta V_{BE}}{\Delta I_B} = \frac{1}{slope}$
 Ω

OUTPUT CHARACTERSTICS STUDY:

1. I_B is set to 50 μA by varying V_{BB} .
2. V_{CE} is varied (a) in steps of 0.1V, starting from zero volt, up to 0.5V and, (b) in steps of 2V up to maximum value of 12V, by varying V_{CC} .
3. The corresponding of collector current I_C are recorded from the Milli-ammeter in each step and entered under Trial- I of tabular column - II.
4. The same repeated but setting $I_B = 100 \mu A$ for Trial-II, and $I_B = 150 \mu A$ for Trial III to begin with, and corresponding readings of I_c are entered in the corresponding tabular column.

COURSE LABORATORY MANUAL

EVALUATION OF THE CONSTANTS:

1. The readings under all 3 trials are plotted on the same graph, with V_{CE} along X-axis, and I_C along Y-axis (Fig. 6.2(b)).
2. The values of I_C at points I_{C1} , I_{C2} , and I_{C3} at which I_C becomes essentially independent of V_{CE} for the three curves are noted .

3. The current gain β in general is given by, $\beta = \frac{\Delta I_C}{\Delta I_B}$, β is evaluated for different combinations of curves,

{For example, for the lower curve pair $\beta = \frac{I_{C2} - I_{C1}}{I_{B2} - I_{B1}}$ } , and the average values of β is found out.

4. The value of α is calculated by using the equation, $\alpha = \frac{\beta}{1 + \beta}$.

5. The output resistance of the transistor is calculated using the formula, $R_o = \frac{\Delta V_{CE}}{\Delta I_C} = \frac{1}{\text{slope}} \Omega$

9. CIRCUIT DIAGRAM:

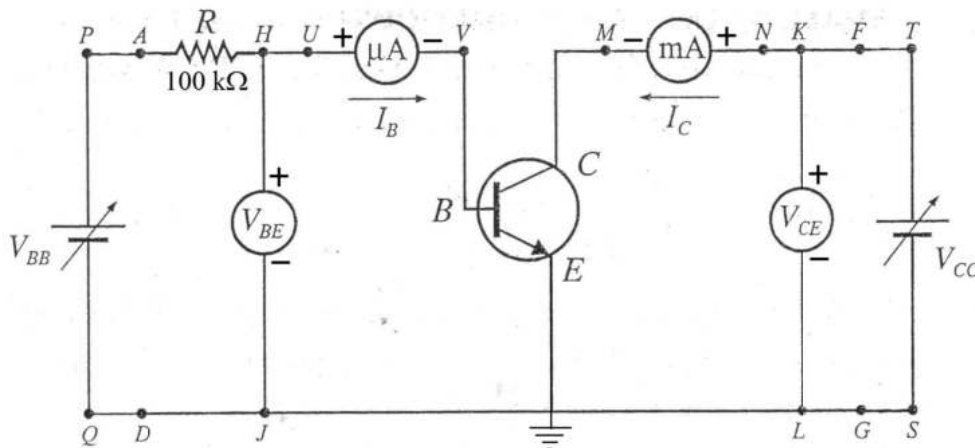

Fig. 6.1: Circuit diagram of NPN transistor in CE mode.



COURSE LABORATORY MANUAL

10. OBSERVATION TABLE:

a) Input characteristics:

TABULAR COLUMN -I

V_{BE} (Volts)	$V_{CE} = 1V$ $I_B (\mu A)$
0.0	
0.1	
0.2	
0.3	
0.4	
0.45	
0.5	
0.55	
0.6	
0.65	
0.7	
0.75	

b) Output characteristics

TABULAR COLUMN -II

V_{CE} (Volts)	Trial-I	Trial-II	Trial-III
	$I_B = 50$ μA I_{C1} (mA)	$I_B = 100$ μA I_{C2} (mA)	$I_B = 150$ μA I_{C3} (mA)
0.0			
0.1			
0.2			
0.3			
0.4			
0.5			
1.0			
2.0			
4.0			
6.0			
8.0			
10.0			
12.0			

From graph I (Similar to Fig. 6.2(a)),

The knee voltage, V_{knee} is found to be = _____ V

11.GRAPHS / OUPUTS:

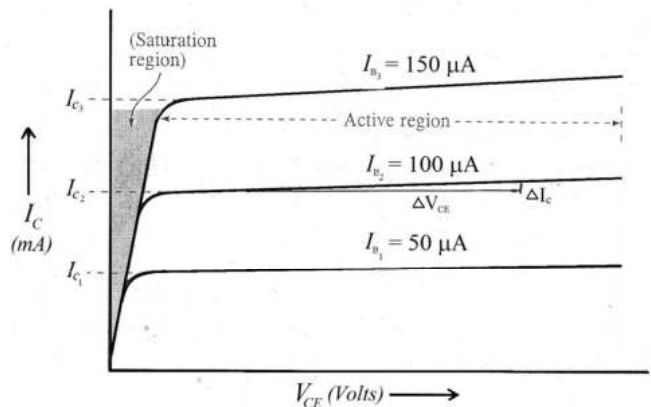
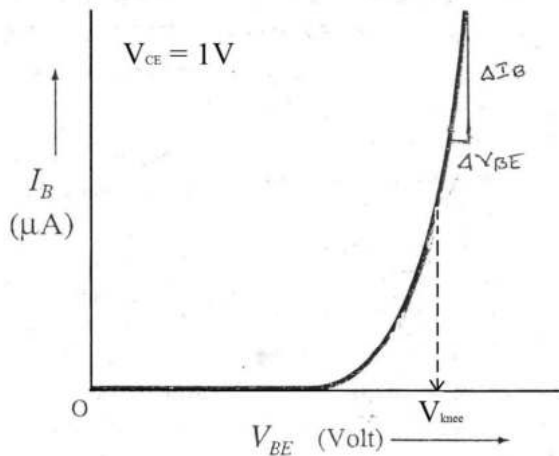

Fig. 6.2: (a) Input characteristics and (b) Output characteristics.



COURSE LABORATORY MANUAL

12. RESULTS & CONCLUSIONS:

For the given transistor,

1. The input and output characteristics are obtained,
2. The knee voltage $V_{knee} = \underline{\hspace{2cm}} V$
3. The input resistance $R_i = \underline{\hspace{2cm}} \Omega$
4. The output resistance $R_o = \underline{\hspace{2cm}} \Omega$
5. The value of $\beta =$
6. The value of $\alpha =$

- Base current is almost zero until V_{BE} reaches a characteristic voltage called, knee voltage (V_{knee}). Further increase in V_{BE} , the I-V curve shows a linear trend.
- Collector current initially increases with increase in V_{BE} and gets saturated at a characteristic value of V_{CE} .

13. LEARNING OUTCOMES:

- The saturation collector current (I_C) of the transistor depends on the input base current (I_B)
- Transistor amplifies the input current and hence it can be used as an amplifier.

14. APPLICATION AREAS:

- Signal amplifiers, power regulators and in equipment controllers.
- Transistors are the main building blocks of integrated circuits

15. REMARKS:

To be written by the student.



COURSE LABORATORY MANUAL

1. EXPERIMENT NO.: 7

2. TITLE: **SERIES AND PARALLEL LCR CIRCUITS**

3. LEARNING OBJECTIVES:

To know resonant frequency.

To study the frequency responses of series and parallel resonance circuit.

To know lower cut off frequency and upper cut off frequency.

4. AIM:

(a) To study the frequency responses of the series and parallel resonance circuit.

(b) To determine the inductance value of the given inductor.

(c) To determine the band width and quality factor of the circuit in series resonance.

5. MATERIAL / EQUIPMENT REQUIRED:

Audio frequency oscillator, AC milli-ammeter, inductor (choke), resistor and capacitor

6. THEORY:

During series resonance current flow in the circuit is given by

$$I = \frac{V}{R_2 + (X_L - X_C)}$$

where X_L is the inductive reactance and X_C is the capacitive reactance and they are equal

$$\text{i.e., } \omega_1 = \frac{1}{\omega_c} \text{ and } 2\pi f_1 = \frac{1}{2\pi f_c}$$

During the resonance, $f = f_r$,

$$f_r = \frac{1}{2\pi\sqrt{LC}} \quad \text{or} \quad L = \frac{1}{4\pi^2 f_r^2 C} \quad \text{----- 1}$$

During parallel resonance the current flow is minimum and is given by $I_{\min} = \frac{V}{L/CR}$. The quality factor Q is defined as the ratio of the energy energy stored in the coil to the energy dissipated in it. and is given by I_{\min} .

$$\text{During the resonance, } f_r = \frac{1}{2\pi\sqrt{LC}} \quad \text{or} \quad L = \frac{1}{4\pi^2 f_r^2 C} \quad \text{----- 2}$$

$$\text{Also, during the resonance, } Q = \frac{1}{R} \sqrt{\frac{L}{C}}$$

'Q' gives the figure of merit and used to compare different coils. In the resonance graph the frequency points are where the power dissipation is half the maximum are marked as f_a & f_b . These points are at on either side of the I_{\max} . Then $\Delta f = (f_b - f_a)$ is called the band width.

$$\text{From the graph, Q can be calculated as, } Q_{\text{graph}} = \frac{f_r}{\Delta f} \quad \text{-----3}$$

There should be a close agreement between the theoretical and graphical Q values. If the bandwidth is small, the 'Q' factor is high. If 'Q' is high, the sensitivity of the particular frequency is (f_r) is high.



COURSE LABORATORY MANUAL

Such series resonance circuits are used to select particular frequency and are called 'acceptor circuits'. Similarly in parallel resonance circuit the current flow is minimum during resonance and hence is used to reject a particular frequency (f_r) and are called 'rejecter circuits'.

7. FORMULA(E) / CALCULATIONS:

Inductance, $L = \frac{1}{4\pi^2 f_r^2 C}$ H, where, f_r is the resonance frequency (Hz), C is the capacitance of the capacitor used(F)

Quality factor, $Q = \frac{1}{R} \sqrt{\frac{L}{C}}$ where, R is the resistance used (ohm), L is the inductance (H), C is the capacitance of the capacitor used (F).

Graphical $Q_{graph} = \frac{f_r}{\Delta f}$, where, f_r is the resonance frequency (Hz)

Band width $\Delta f = f_b - f_a$ where, f_a and f_b is the lower and upper cut off frequencies (Hz)

In series resonance:

$$L_s = \frac{1}{4\pi^2 f_r^2 C} = \text{_____ H}$$

In parallel resonance:

$$L_p = \frac{1}{4\pi^2 f_r^2 C} = \text{_____ H}$$

1) Mean inductance, $L = \frac{L_s + L_p}{2} = \text{_____ H}$

2) Band width, $\Delta f = (f_b - f_a) = \text{_____ Hz}$

3) Theoretical, $Q = \frac{1}{R} \sqrt{\frac{L_s}{C}} = \text{_____}$

4) Graphical, $Q_{graph} = \frac{f_r}{\Delta f} = \text{_____}$

8. PROCEDURE:

1. The required circuit is done as in the Fig. 7.1(a) (series resonance).
2. The supply points are switched ON and the output of the oscillator is adjusted approximately 10V throughout the experiment.
3. Frequency f is increased from 200Hz to 1kHz in steps and corresponding current flow is noted.
4. For maximum current, resonance frequency, ' f_r ' must be determined with maximum accuracy.
5. A graph of I v/s f is plotted as shown in the Fig. 7.1(b). The resonance frequency as well as inductance value of the coil is determined using Eqn. (1) .

COURSE LABORATORY MANUAL

6. The quality factor Q of the circuit also evaluated using Eqn. (3).
7. For parallel resonance, the circuit is done as in Fig. 7.1(c). The frequency corresponding to the minimum current is determined.
8. The readings are plotted as in the Fig. 7.1(d). And hence, the unknown inductance value is determined using Eqn. (2).

9. CIRCUIT DIAGRAM:

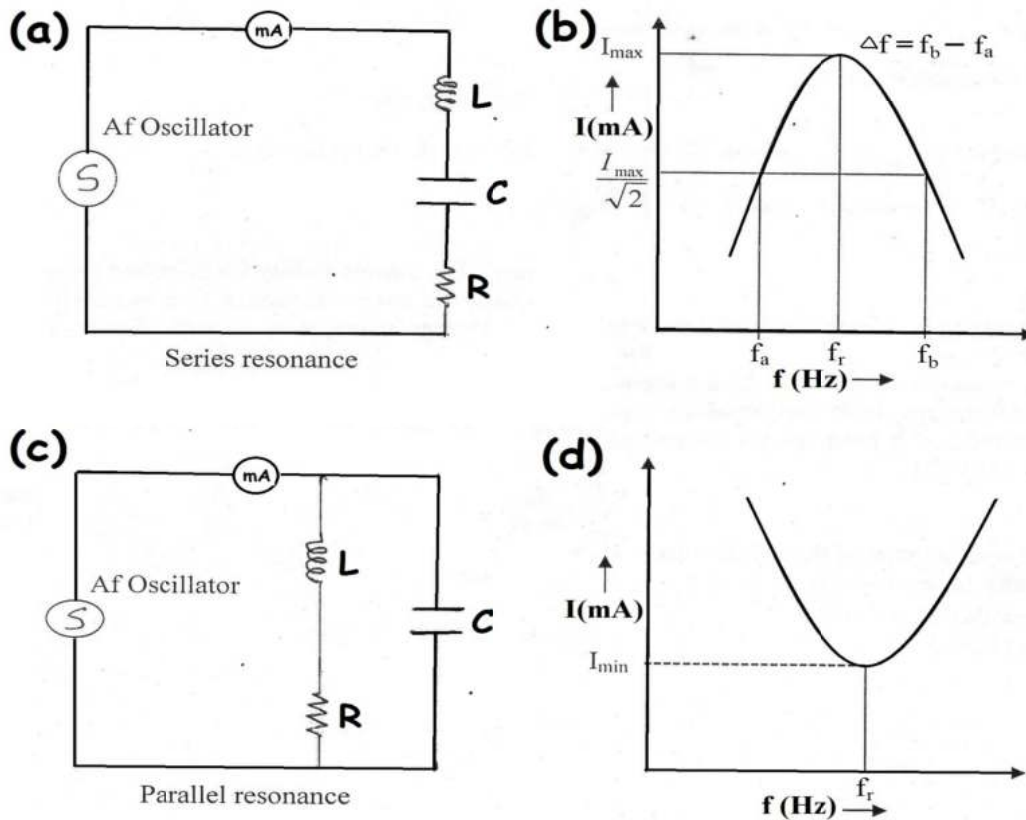

Fig. 7.1: (a) Series LCR circuit, (b) plot of I v/s f for series resonance, (c) parallel LCR circuit, (d) plot of I v/s f for parallel resonance



COURSE LABORATORY MANUAL

10. OBSERVATION TABLE:

Series resonance

R = _____ ohms

C = _____ F

Parallel resonance

R = _____ ohms

C = _____ F

Frequency (Hz) f	In series resonance	In parallel resonance
	Current (mA) I	Current (mA) I
0		
200		
240		
..		
..		
..		
960		
1000		

Series resonance

$f_r =$ _____ Hz

$I_{max} =$ _____ mA

$\frac{I_{max}}{\sqrt{2}} =$ _____ mA

Parallel resonance

$f_r =$ _____ Hz

$I_{min} =$ _____ mA

11. GRAPHS / OUPUTS:

In the graph corresponding to the series resonance circuit, as the frequency is increased, initially, the current in the circuit increases rapidly. As the frequency is further increased, the extent of increase in the circuit current decreases and reaches a maximum value. At higher frequencies, the current starts decreasing gradually followed by rapid decrease. The resulting curve has a bell shape.

In the graph corresponding to the parallel resonance circuit, as the frequency is increased, initially, the current in the circuit decreases rapidly. As the frequency is further increased, the extent of decrease in the circuit current decreases and reaches a minimum value. At higher frequencies, the current starts increasing gradually followed by rapid increase. The resulting curve has a inverted bell shape.

12. RESULTS & CONCLUSIONS:

a) The inductance value of the given inductor, L = _____ H

b) Band width = _____ Hz

c) Quality factor, Q (theoretical value) = _____

d) Quality factor, Q (graphical value) = _____

It is observed that the quality factor obtained by the experiment is in agreement with the theoretical value.



COURSE LABORATORY MANUAL

13. LEARNING OUTCOMES:

- Resonance in series resonance circuit occurs when current in the circuit is maximum.
- Resonance in parallel resonance circuit occurs when current in the circuit is minimum.

14. APPLICATION AREAS:

- Tuning circuits of the radio and television.
- Oscillators, filters and amplifiers

15. REMARKS:

To be written by the student.



COURSE LABORATORY MANUAL

1. EXPERIMENT NO:8
2. TITLE: Y - BY CANTILEVER BENDING
3. LEARNING OBJECTIVES: <ul style="list-style-type: none">i. Students should be able to differentiate between Elastic and Plastic behaviors and materials.ii. To understand Hooke's Law.iii. To know the definitions for Stress, Strain, elastic modulus and units of their measurements.
4. AIM: <p>To determine the Young's modulus "Y" of the material of a cantilever by measuring the depression of its loaded end.</p>
5. MATERIAL / EQUIPMENT REQUIRED: <p>Uniform bar, G Clamp, weight hanger, traveling microscope etc</p>
6. THEORY : <p>Young's modulus is named after a British scientist, Thomas Young. Young's modulus is defined in the elastic region (initial linear part) of the Stress-Strain plot, as the ratio of the Longitudinal Stress over Longitudinal Strain. In the elastic range, stress is directly proportional to strain is known as, Hooke's law. It is a measure of stiffness of elastic material.</p> <p>If a wire of length 'L' and area of cross-section 'a' be stretched by a force 'F' and if a change (increase) of length 'l' is produced, then,</p> $\text{Young 's modulus} = \frac{\text{Normal stress}}{\text{Normal strain}} = \frac{F/a}{l/L}$ <p>In the case of a light cantilever, the young's modulus is given by $Y = \frac{Wl^3}{3XI}$ where I is the geometrical moment of inertia of the bar and $I = \frac{bd^3}{12}$ Here b, d and l are the breadth, thickness and length of the bar respectively, X is the depression at the loaded end of the bar for weight $W = Mg$. Then $Y = \frac{4Mgl^3}{bd^3X}$</p>
7. FORMULA / CALCULATIONS: $Y = \frac{4Mgl^3}{bd^3X} \quad N/m^2$ <p>Y – is the Young's modulus of the material of the bar (N/m²) g - is the acceleration due to gravity = 9.8 m/s² (data given) M – is the mass kept on the weight hanger (kg) d - is the thickness of the given bar (m) (data given) b – is the breadth of the given bar (m) (data given) X – is the depression at the beam due to mass M, (m)</p>
8. PROCEDURE : <p>The given bar AB is fixed rigidly at one end using a G – Clamp so that it is perfectly horizontal. A weight hanger and a pin are fixed at the free end of the bar. Mass at the hanger in steps and the depression at the free end of the bar is noted using TMS (vertical scale). The readings are repeated when the load is decreased in the same equal steps. The given value of breadth and thickness are noted. The Young's modulus of the bar is calculated according to the formula.</p> $Y = \frac{4Mgl^3}{bd^3X}$



COURSE LABORATORY MANUAL

9. BLOCK DIAGRAM :

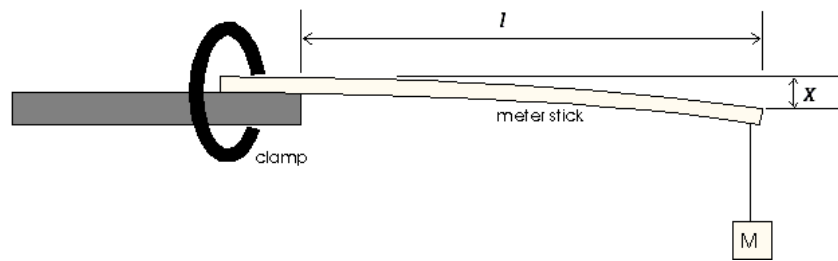

10. OBSERVATION TABLE:

(1) Measurement of mean depression X:

Least count (L.C.) of Traveling Microscope (TM):

Value of 1MSD = _____ cm

Total no. of VSD = _____

$$L.C = \frac{\text{Value of 1MSD}}{\text{total no. of VSDs}} = \text{_____ cm}$$

Load (kg)	T.M.S reading (cm)						Mean (cm)	Depression/0.1kg X (cm)
	Load Increasing			Load decreasing				
	MSR	CVD	TR	MSR	CVD	TR		
W + 0								
W + 0.05								
W + 0.1								
W + 0.15								
W + 0.2								
W + 0.25								

$$\text{Mean X} = \text{-----cm}$$

$$= \text{-----m}$$

$$TR = MSR + (CVD \times LC)$$

Calculations:

$$M = \text{----- kg}$$

$$g = 9.8 \text{ m/s}^2$$

$$l = \text{-----m}$$

$$b = \text{-----m}$$

$$d = \text{-----m}$$

$$X = \text{-----m}$$



COURSE LABORATORY MANUAL

Young's modulus $Y = \frac{4Mgl^3}{bd^3X}$ = -----N/m ²
11. OUTPUTS: Readings of traveling microscope for different loads obtained during consecutive loading and unloading steps.
12. RESULTS & CONCLUSIONS: Young's modulus of the material of the bar $Y = \text{-----N/m}^2$
13. LEARNING OUTCOMES : The determined Youngs modulus of the wooden scale is in agreement with standard value and it is used as a load bearing structure with suitable shapes and dimensions
14. APPLICATION AREAS: <ul style="list-style-type: none">• Young's modulus measurement is required in civil engineering because the knowledge of the elasticity modulus of high-strength concrete is very important in avoiding excessive deformation, providing satisfactory serviceability and achieving the most cost-effective designs.• Materials in mechanical and aerospace engineering are chosen based on their strength. Since young's modulus determines the strength of the material, its measurement is essential in these fields.
15. REMARKS:



COURSE LABORATORY MANUAL

1. EXPERIMENT NO:9

2. TITLE: **OPTICAL FIBER**

3. LEARNING OBJECTIVES:

To study light gathering capacity of the given optical fiber in the context of total internal reflection.

4. AIM:

To determine acceptance angle and Numerical aperture of an optical fiber.

5. MATERIAL / EQUIPMENT REQUIRED:

Single strand plastic optical fibers of different core diameter/length, Laser Source, screen

6. THEORY:

Numerical aperture represents the light gathering capacity of an optical fiber.

It is given by $N.A = n_o \sin\theta_A = \sqrt{n_1^2 - n_2^2}$

Here n_o is the refractive index of the medium from which light is entering.

θ_A is the angle of acceptance

n_1 is the refractive index of the core

n_2 is the refractive index of cladding

7. FORMULA / CALCULATIONS:

$$\theta_A = \tan^{-1}\left(\frac{D}{2L}\right)$$

Where,

θ_A =Acceptance angle($^\circ$)

D=Diameter of the spot(m)

L=Distance between the screen & the optical fiber end(m).

Numerical aperture is given by $N.A = n_o \sin.\theta_A$

Where, n_o =Refractive index of the surrounding medium

8. PROCEDURE :

1. Connect the fiber to the Laser source.

2. Take the other end of the fiber and project the light output on to the screen to obtain a bright Circular spot of size say 5mm.

3. Determine the diameter D of the bright spot and the distance L from the fiber end to the screen and measure the diameter of the spot (D) and the distance between the screen & the optical fiber end (L).

4. Calculate the acceptance angle using the formula

$$\theta_A = \tan^{-1}\left(\frac{D}{2L}\right)$$



COURSE LABORATORY MANUAL

5. Numerical aperture is given by $N.A = n_0 \sin \theta_A$

Here n_0 is the refractive index of the medium from which light is entering ($n_0 = 1$ for air).

6. Now for the same fiber repeat this procedure for at least four other values of distance L and calculate the acceptance angle and numerical aperture in each case. Finally take the average of the four numerical aperture values.

7. Now repeat the above procedure for the remaining fibers.

8. Refer the catalog and find out refractive index of core and cladding (n_1 & n_2) and evaluate numerical aperture using the formula $N.A = \sqrt{n_1^2 - n_2^2}$ and compare it with the experimental value

9. BLOCK DIAGRAM:

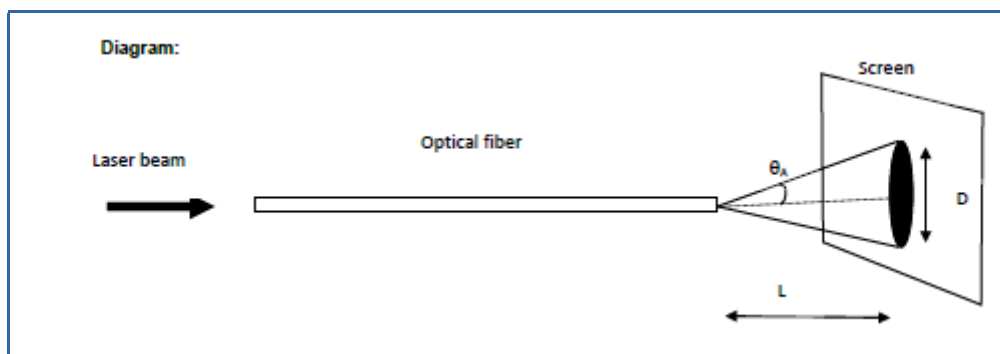

10. OBSERVATION TABLE :

Tr.no	Diameter of the sopt 'D' (m)	Distance between screen and optical fiber end 'L' (m)	Angle of acceptance $\theta_A = \tan^{-1}(\frac{D}{2L})$	Numerical Aperture $N.A. = n_0 \sin \theta_A$
1				
2				
3				
4				

11. OUTPUTS:

Estimation of angle of acceptance and numerical aperture using measured data

12. RESULTS & CONCLUSIONS:

1. The acceptance angle of the optical fiber is=
2. The Numerical aperture for the given optical fiber is found to be=



COURSE LABORATORY MANUAL

13. LEARNING OUTCOMES :

For varied distances between screen and optical fiber corresponding angle of acceptance and numerical aperture was calculated

14. APPLICATION AREAS:

Electronics, communication industry, medical industry and construction

15. REMARKS:



COURSE LABORATORY MANUAL

1. EXPERIMENT NO:10

2. TITLE: **MAGNETIC FIELD INTENSITY**

3. LEARNING OBJECTIVES:

To study variational behavior of magnetic field and its consequences as a function of current.

4. AIM:

To determine Magnetic field Intensity at the center of a circular coil carrying current (by deflection method)

5. MATERIAL / EQUIPMENT REQUIRED:

Circular coil, Power supply, Switching keys, Magnetic needle, Sliding compass box

6. THEORY :

Magnetic field Intensity at any point on the axis of a plane circular current loop

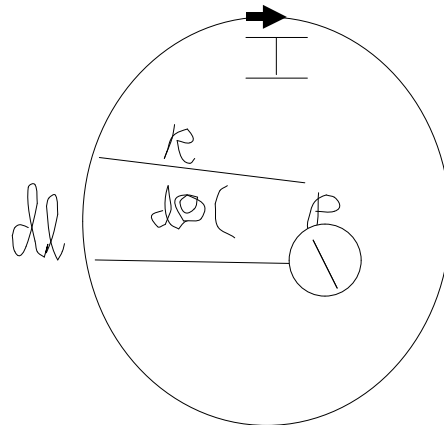

Consider a current loop of radius R carrying current I. For the small current element dl subtending an angle θ , the flux density at P is

$$dB = \vec{dB} = \frac{\mu I dl \sin \theta}{4\pi r^2}$$

$$dl = R d\theta$$

$$\vec{dB} = \frac{\mu I R d\theta}{4\pi r^2}$$

$$\vec{B} = \int dB = \frac{\mu I}{4\pi R} \int_0^{2\pi} d\theta$$

$$\vec{B} = \frac{\mu I}{2R} \hat{a}$$

$$\vec{H} = \frac{I}{2R} \hat{a}$$

The direction is perpendicular to plane containing dl and the radius vector and in to the page.

A vertical circular coil carrying current produces a magnetic field at right angles to the plane of the circle. The plane of the circle is placed in magnetic meridian so that the magnet experiences a couple twisting it out of the meridian, while the Earth's horizontal component of magnetic field B_H tends to retain it in the meridian.



COURSE LABORATORY MANUAL

Deflecting couple = $B_{Coil}.m.\cos \theta$

Restoring couple = $B_H .m.\sin \theta$

Here m is the magnetic moment of the magnet of the magnetometer

$$B_{Coil}.m.\cos \theta = B_H .m.\sin \theta$$

$$\mu H = B_H .\tan \theta$$

$$H = \frac{B_H}{\mu} \tan \theta$$

$$H_{centre} = \frac{nI}{2r}$$

$$Current = \frac{2rH}{n}$$

7. FORMULA :

$$H = \frac{B_H}{\mu} \tan \theta$$

Where H=Magnetic field intensity(A/m)

B_H = Earth's horizontal component of magnetic field(T)

μ =Permeability(H/m)

8. PROCEDURE :

1. The coil is set in magnetic meridian by orienting the plane of the coil parallel to the north-south direction. Place the eye little above the coil and rotate the instrument till the coil, magnetic needle and its image in the mirror lie in same vertical plane.
2. Rotate the magnetometer so that the pointer reads 0^0-0^0 .
3. Connect the circuit as shown in the figure.
4. Adjust the current so the magnetometer gives a deflection of the order 60^0-70^0 .
5. Reverse the current and note the deflection without parallax.

9.CIRCUIT DIAGRAM :

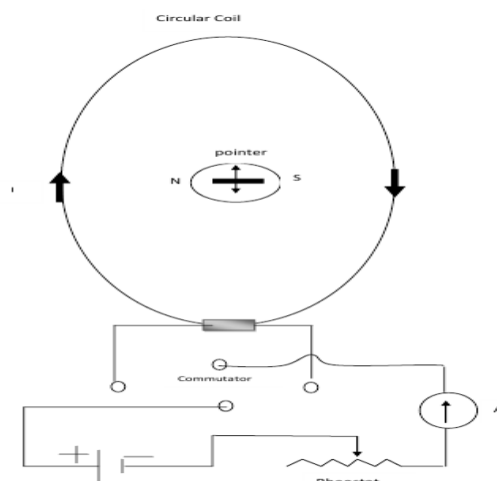



COURSE LABORATORY MANUAL

10. TABULAR COLUMN:

OBSERVATIONS:

Permeability of free space $\mu_0 = 4\pi \times 10^{-7} \text{ H/m}$

Relative permittivity $\mu_r = 1$ (for Air)

Number of turns in the circular coil $n = \dots\dots\dots$

Magnetic field Intensity:

$$H = \frac{B_H}{\mu} \tan \theta$$

B_H is the Horizontal component of Earth's field = $0.36 \times 10^{-4} \text{ T}$

Tr. no	Current I (A)	Magnetometer reading θ (deg)		Average deflection	Tan θ	H (A/m)
		Direct	Reverse			

11. GRAPH/ OUTPUTS:

Magnetic field intensity for different values of current at the center of the coil is calculated

12. RESULTS & CONCLUSIONS:

The Magnetic field Intensity at the center of the coil for current values between 0.1 A to 0.25 A isA/m

13. LEARNING OUTCOMES :

The value of the magnetic intensifies with increase in current

14. APPLICATION AREAS:

Electromagnetics, Communication and Medicine and Construction

15. REMARKS:



COURSE LABORATORY MANUAL

1. EXPERIMENT NO:11

2. TITLE: **DETERMINATION OF SPRING CONSTANT**

3. LEARNING OBJECTIVES:

To study the spring constant there by inferring the stiffness of the spring and behavior of spring in different configuration

4. AIM:

- To determine Spring constant for the material of the given spring
- To determine Spring constant in series and parallel combination by plotting Force – Elongation graph

5. MATERIAL / EQUIPMENT REQUIRED:

Given springs, slotted weights

6. THEORY :

Elastic materials are those which retain their original dimensions after the removal of deforming forces. Application of a force on a spring causes elongation. When subjected to stress, strain is produced. Within the elastic limit, the ratio of stress to strain is a constant known as modulus of elasticity. The restoring force is always directed opposite to displacement. Hence The spring performs Simple Harmonic motion.

Restoring force \propto – displacement

$$F = -k x$$

Here k is the proportionality constant known as spring constant. It is a relative measure of stiffness of the material.

7. FORMULA / CALCULATIONS:

$$F = -k x$$

$$K_{\text{series}} = \frac{k_1 \cdot k_2}{k_1 + k_2}$$

$$k_{\text{parallel}} = k_1 + k_2$$

where,

F= Restoring force (N)

k= Spring Constant(N/m)

x= Displacement (m)

k_1 and k_2 = Spring constants of springs 1 and 2

K_{series} and K_{parallel} = Effective spring constants in series and parallel respectively

8. PROCEDURE :

- Connect the given spring to a rigid support.
- Add slotted weight at the other end. Note down the displacement. Increase the weight in steps of 100g .Find spring constant k.
- Find spring constant by setting up Simple harmonic oscillations.
- Connect the two springs in series combination and repeat the above activity and calculate k_{series} .
- Connect the two springs in parallel combination and repeat the above activity and calculate k_{parallel} .
- Plot Force versus displacement graph and find slope.



COURSE LABORATORY MANUAL

9. BLOCK DIAGRAM :

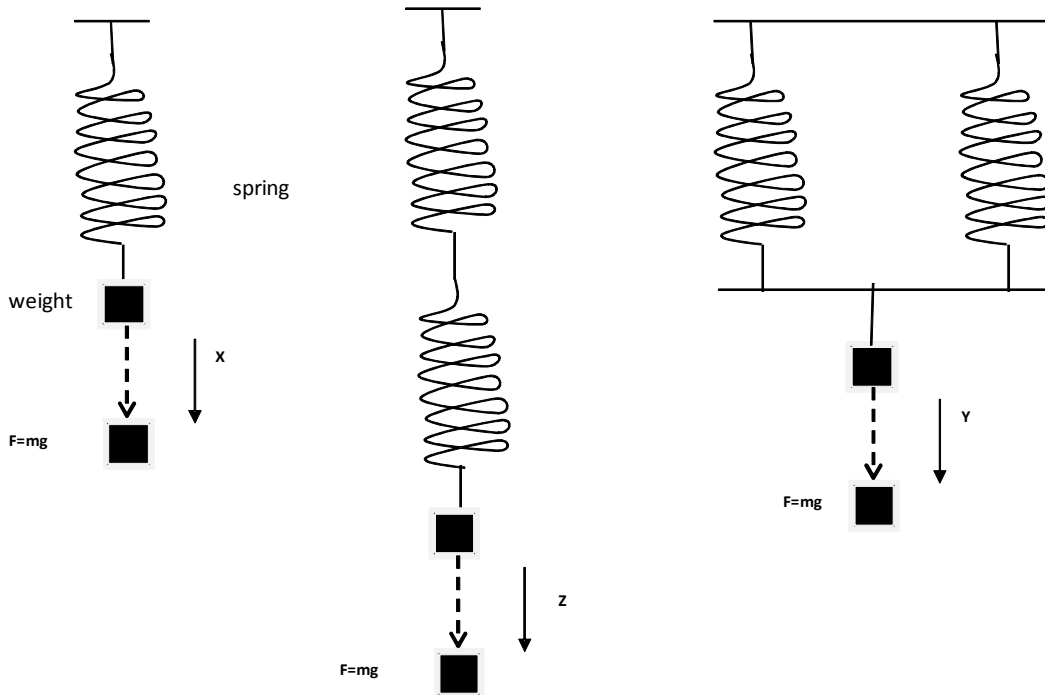

10. OBSERVATION TABLE :

TO DETERMINE K_1 OF SPRING S_1 :

Tr no	Mass (Kg) m	F = mg (N)	Displacement X (m)	Elongation Δx (m)	Spring constant $K_1=F/\Delta x$ (N/m)
1	W				
2	W+0.05				
3	W+0.10				
4	w+0.15				
5	w+0.20				

Mean K_1 = N/m



COURSE LABORATORY MANUAL

TO DETERMINE K_2 OF SPRING S_2

Tr no	Mass (Kg) m	F = mg (N)	Displacement X (m)	Elongation ΔX (m)	Spring constant $K_2=F/\Delta x$ (N/m)
1	W				
2	W+0.05				
3	W+0.10				
4	w+0.15				
5	w+0.20				

Mean $K_2 = \dots\dots\dots$ N/m

TO DETERMINE K_s IN SERIES COMBINATION

Tr. no	Mass (Kg) m	F = mg (N)	Displacement (m)	Elongation ΔX (cm)	Spring constant K from the graph (N/m)	Spring constant K_s theoretical $K_s = (K_1 K_2 / K_1 + K_2)$ N/m
1	W					
2	W+0.05					
3	W+0.10					
4	w+0.15					
5	w+0.20					

TO DETERMINE K_p PARALLEL COMBINATION

Tr. no	Mass (Kg) m	F = mg (N)	Displacement (m)	Elongation ΔX (m)	Spring constant K from the graph (N/m)	Spring constant K_s theoretical $K_p = (K_1 + K_2)$ N/m
1	W					
2	W+0.05					
3	W+0.10					
4	w+0.15					
5	w+0.20					



COURSE LABORATORY MANUAL

11. GRAPHS :

Force – Elongation graph

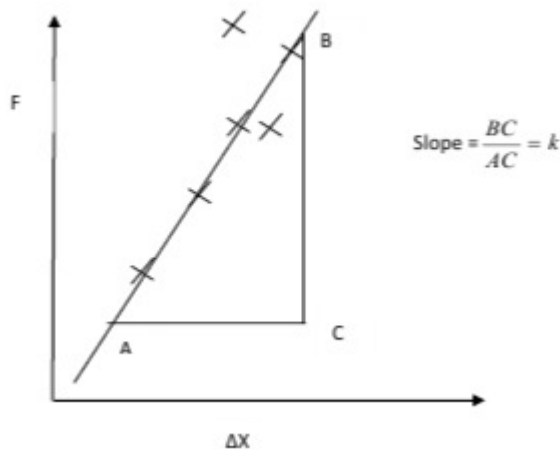

12. RESULTS & CONCLUSIONS:

The Spring constant K_1 of the given spring S_1 isN/m and Spring constant K_2 of the given spring S_2 isN/m

The Spring constant of the given material spring from graph for Series combination K_s isN/m and theory isN/m

The Spring constant of the given material spring from graph for Parallel Combination K_p isN/m and theory isN/m

13. LEARNING OUTCOMES:

Relationship of springs connected in series and parallel was determined and the equivalent spring constant was determined using different weights

14. APPLICATION AREAS:

In mechanical equipments and construction technology

15. REMARKS:



COURSE LABORATORY MANUAL

1. EXPERIMENT NO.: 12

2. TITLE: **NEWTON'S RINGS**

3. LEARNING OBJECTIVES:

- To know about the interference phenomenon.
- To know about the monochromatic source and coherency.
- In order to develop the skill to observe the sensitive optical phenomenon.

4. AIM:

To determine the radius of curvature of the Plano convex lens by forming Newton's rings.

5. MATERIAL / EQUIPMENT REQUIRED:

Plano convex lens, optically plane glass plates, traveling microscope, sodium vapour lamp and turnable glass plate.

6. THEORY:

In general for interference phenomena, we talk about the path difference of two light waves. This is simply the relative difference in distance travelled by the two waves, measured in numbers of wavelengths, plus a correction for any phase changes that might occur on reflections. It is easy to see that the condition for constructive interference is that the path difference, Δ , satisfies: $\Delta = m\lambda$, where $m = 1, 2, 3, \dots$. Similarly, for destructive interference, $\Delta = (m+1)\lambda/2$, where $m = 1, 3, 5, \dots$

In Fig. 12.1, consider a plano-convex lens MQN is placed over a plane glass plate XY with point of contact Q. The dotted arc MN is part of the circle formed by the surface of the lens. Thus, OQ is the radius of curvature of the lens, 'R'. Let the solid circle passing through A be a ring formed having a radius PA.

When a ray, DA is incident on the interface of air and lens at point A, a certain portion of light is reflected along path AE and remaining portion of light is refracted to enter air medium along path AC. The ray AC reaches a point (C) in the glass plate through the air wedge and gets reflected to reach at a point B in the lens. Then again this ray CB is refracted in lens medium and emerges out towards F in air medium. Due to the superposition of the rays AE and BF interference occurs. Whether the interference is constructive or destructive depends on the phase shift of two rays. If constructive interference occurs due to the superposition of AE and BF, this circle turns out to be a bright ring. If the interference is destructive then the circle turns out to be a dark ring. For a given set of wavelength of the light source and radius of curvature of the lens, successive dark and bright rings forms at different 't' positions. This co-centric ring pattern is known as 'Newton's ring'.

COURSE LABORATORY MANUAL

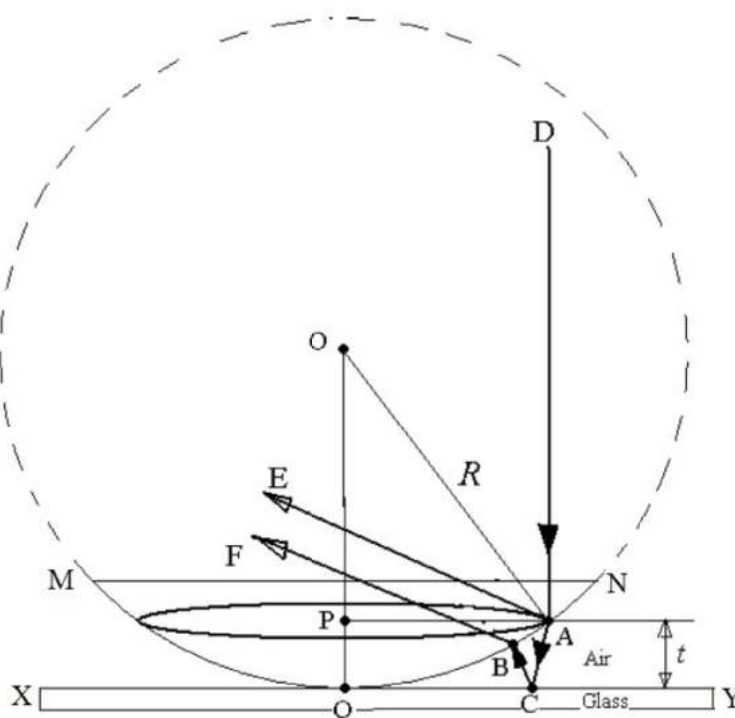

Fig. 12.1: Plano-convex lens (MQN) on a plane glass plate (XY).

Phase shift occurs due to two basic reasons, (i) the path difference between the two rays and (ii) the reflection of ray AC on the interface of air and glass. Further, considering the geometry of the lens-plate arrangement, below equation for the calculation of radius of curvature of the lens is obtained.

Radius of curvature of the lens,

$$R = \frac{D_m^2 - D_n^2}{4\lambda(m - n)}$$

where, 'D_m' and 'D_n' are the diameter of mth and nth dark rings, 'λ' is the wavelength of sodium light = 589.3x10⁻⁹m and, m and n are the ordinal numbers of any two different rings.

7. FORMULA(E) / CALCULATIONS:

To determine the radius of curvature of the convex surface of the lens:

$$\text{Radius of curvature, } R = \frac{D_m^2 - D_n^2}{4\lambda(m - n)}$$

where, 'D_m' and 'D_n' are the diameter of mth and nth dark rings(m), 'λ' is the wavelength of sodium light = 589.3x10⁻⁹m and, m and n are the ordinal numbers of any two different rings and (m - n) = 4

8. PROCEDURE:

1. Microscope is focused to get the clear image of the cardboard sheet pasted on the wooden plank.
2. The given Plano convex lens is to be kept on the plane glass plate such that the convex side of the lens is in contact with the glass plate.
3. Now this lens set is to be kept on the wooden plank, such that the objective lens of the microscope is directly above the lens set.
4. The turnable glass plate is rotated until field of view of the microscope becomes bright, now the

COURSE LABORATORY MANUAL

plane of the turnable glass plate makes an angle of 45° to incident light from the sodium vapor lamp. This arrangement is required to make the light to fall normally over the lens set. Now the Newton's rings are observed in the field of view.

- The microscope is adjusted such that the cross wire coincides with the center of the Newton's rings
- By rotating the head screw cross wire is made to coincide with the 12th dark ring in L.H.S and microscope readings are taken, in the same manner readings are taken for the alternate dark rings up to the R.H.S 12th ring.
- Then the diameters ' D_m ' and ' D_n ' of various dark rings are calculated. The radius of curvature R of the convex surface of the lens can be calculated using the formula,

$$R = \frac{D_m^2 - D_n^2}{4\lambda(m - n)}$$

where, ' D_m ' and ' D_n ' are the diameter of mth and nth dark rings, ' λ ' is the wavelength of sodium light = 589.3×10^{-9} m and, m and n are the ordinal numbers of any two different rings.

9. BLOCK DIAGRAM:

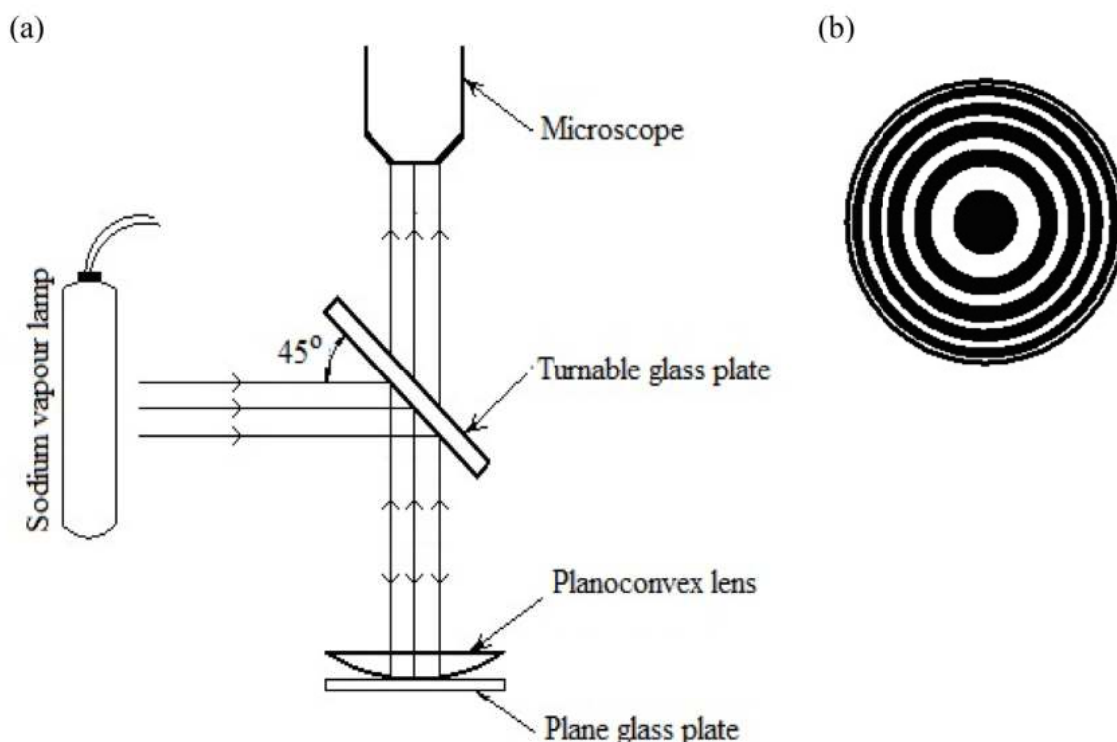

Fig. 12.2: (a) Experimental arrangement for Newton's ring and (b) typical Newton's rings.

10. OBSERVATION TABLE:

No of rotations given to the screw head = _____

Displacement along the pitch scale = _____ cm



COURSE LABORATORY MANUAL

$$\text{Pitch} = \frac{\text{Displacement}}{\text{no. of rotations}} = \text{_____ cm}$$

$$\text{LC} = \frac{\text{Pitch}}{\text{No. of HSDs}} = \text{_____ cm}$$

Rings No	T M Readings(cm)						Diameter of the Rings D = (a-b) (m)	D ² (m ²)	(D _m ² - D _n ²) ((m-n)=4) (m ²)
	Left (a)			Right (b)					
	PSR (cm)	HSR	TR (cm)	PSR (cm)	HSR	TR (cm)			
12									
10									
08									
06									
04									
02									

$$\text{TR} = \text{PSR} + (\text{HSR} \times \text{LC})$$

$$\text{Mean value of } (D_m^2 - D_n^2) = \text{_____ m}^2$$

11. OUPUTS:

The differences in the squares of diameter values (last column of the table) are found to be approximately same. This indicates that as the ring number (first column of the table) is increased the corresponding values of the squares of the ring diameters (9th column of the table) increase linearly.

12. RESULTS & CONCLUSIONS:

Radius of curvature of the convex surface of the given plano convex lens = _____ m

- The value obtained is in agreement with the data provided by the supplier. This proves that by Newton's ring method, one can accurately find out the unknown value of radius of curvature of a given lens.

13. LEARNING OUTCOMES:

- Students are expected to understand the interference phenomenon.
- Knowledge about the monochromatic source.
- Optical method is one of the accurate method to find out a physical parameter.

14. APPLICATION AREAS:

This method is used to; measure wave length of the unknown light, refractive index of liquids, radius of curvature of lens.

15. REMARKS: